

# TRIUMPH

## REPLACEMENT PARTS

### CATALOGUE NO. 2

*for*

TWENTY-ONE (3TA)  
SPEED TWIN (5TA)  
From Engine No. H 5485

1959

TRIUMPH ENGINEERING COMPANY LIMITED  
MERIDEN WORKS · ALLESLEY · COVENTRY · ENGLAND  
TELEPHONE MERIDEN 331      TELEGRAMS "TRUSTY COVENTRY"

## PREFACE

**B**EFORE ordering parts for your machine, please read very carefully the instructions contained in the next paragraph. In a large number of cases, the information given in orders is not sufficient to enable us to identify customers' requirements with certainty. Delay is frequently occasioned by our having to refer the order back for further particulars before we can supply.

**HOW TO ORDER.** Every part is indicated by number, and this should be quoted together with the description. In order to assist customers, dimensions have been given in many cases where parts are similar. Parts where possible have been listed in order of assembly and a number of the illustrations show the assembly order also. With these aids there should be no difficulty in identifying the parts you require. Always head your order with the engine number, stamped on the drive side of the crank case underneath the cylinder flange, together with the prefix letters. Use a separate sheet for your order if you are sending a letter as well.

### SPECIMEN ORDER

25/2/59

To Triumph Engineering Co. Ltd.,  
Spares Department,  
Meriden Works,  
Allesley,  
Coventry.

Engine No. 3TA-H5530

Please supply :—

1 - CP.164/20 - Piston Assy. + .020"  
1 - E3208 - Guide, inlet valve

\*Send C.O.D.

Wm. Smith,  
1a, Ewell Avenue,  
Ewell, Surrey.

*\*For terms of business see page 3.*

**TELEGRAPHIC ORDERS.** Orders by telegram should be addressed to "Trusty 60221 Coventry." They are then telephoned to us, which prevents delay in delivery. It is only necessary to quote part numbers in telegraphic orders, the description can be omitted.

**PATTERNS AND PARTS FOR REPAIR.** It is not necessary to send patterns if the part number is quoted. The sending of patterns often delays the order as parcel post or rail takes longer than letter post.

Parts sent to Coventry for repair, replacement or as patterns should bear the sender's name and address and clear instructions should accompany the parts. All parts must be forwarded carriage paid and care should be taken to ensure that all remittances are sent separately and not enclosed with the parts. Fragile units such as cylinders, etc., should always be boxed to avoid damage in transit. Complete machines should have all fittings such as horns, driving mirrors, tools, etc., removed by the sender before despatch, as it is impossible for us to accept responsibility in the event of loss in transit. We are always pleased to give estimates for overhauling and repairs, but should an estimate not be accepted, a charge will be made covering cost of dismantling and re-assembling, if carried out.

Communications relating to Parts should be addressed to the SPARES MANAGER and for repairs, guarantee claims and technical advice to the SERVICE MANAGER, Triumph Engineering Co. Ltd., Meriden Works, Allesley, Coventry. In order to facilitate quick reference, the quoting of any number, invoice number or reference from previous communications is of essential importance. **Accessories not of our manufacture should be sent direct to the actual makers, whose names and addresses appear on Page 55.**

**WHERE TO OBTAIN.** Triumph Spare Parts may be obtained from any Triumph Dealer, and we recommend our customers to place their orders with the Triumph Dealer in their district, as we do not normally supply direct. When parts not usually asked for are required, and for which the Dealer may have to wire or obtain specially, the postage or carriage incurred becomes payable.

We are not able to supply Transfers as originally affixed to Triumph Motor Cycles, but we are at all times willing to supply a transfer denoting that the machine is of genuine Triumph manufacture, provided the Frame and Engine prefix letters and numbers are quoted.

Customers are warned against the risk incurred by purchasing parts that are not of genuine Triumph manufacture. This risk is eliminated if parts are ordered as instructed, either from our recognised Dealers, or direct from the Spares Department, Meriden Works, Allesley, Coventry.

---

## TERMS OF BUSINESS

**T**HE most convenient method of paying for Spare Parts is by the C.O.D. system. By this method you pay the postman for the goods when he delivers them to you. As the minimum C.O.D. collection fee is 1/2, only goods to the value of 2/- and over can be sent by this system. We do not despatch goods by rail C.O.D.

Where goods are not sent C.O.D., cash must accompany the order. All remittances should be made payable to the Triumph Engineering Co. Ltd., and crossed "Barclays Bank Ltd." if in the form of Postal Order or cheque. Letters containing currency notes must be registered.

Should a remittance be forwarded by telegraphic money order, the name and address of the sender must be inserted in the space provided on the Post Office requisition form for a private message from remitter to payee. Unless this is complied with the Post Office omit such information from the telegram and we are not then in a position to trace the sender.

Postage, carriage and packing is charged at 5% on the value of the goods, minimum charge 1/-. Packing boxes, cases, crates, etc., are charged for at cost and are returnable.



'TWENTY-ONE' 350 c.c. (21 cu. ins.) O.H.V. TWIN

# TRIUMPH

*The Best Motorcycle in the World.*

SPEED TWIN 500 c.c. (30.5 cu. ins.) O.H.V. TWIN

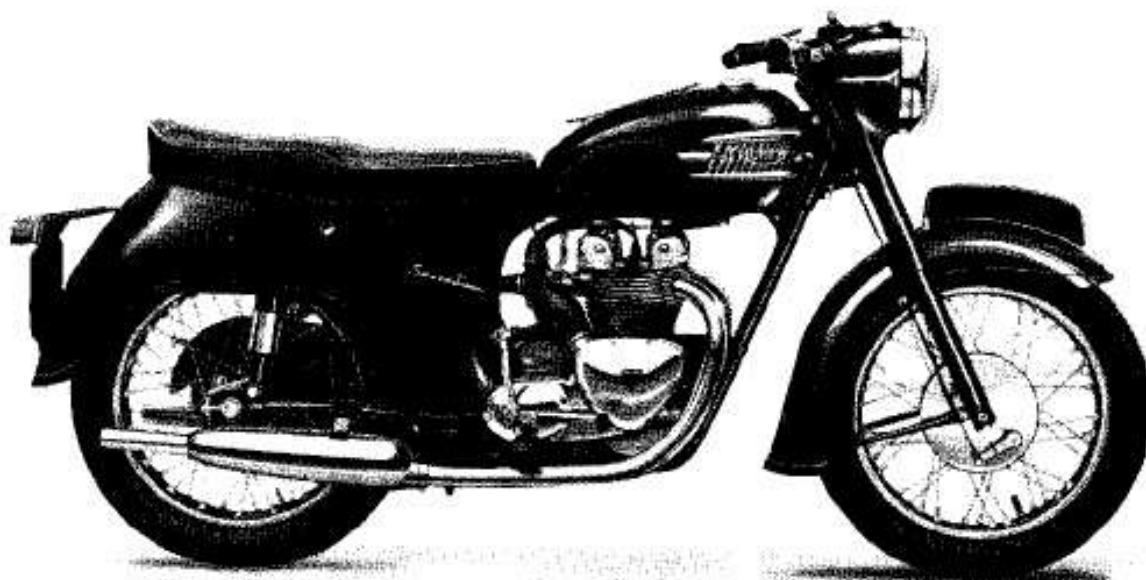

## CARTON PACK — GROUP I

### CARTON PACK COMPONENT LIST—GROUP I

The following sub-assemblies are supplied in carton packs under the C.P. part number stated. The contents of these carton packs are preserved and will not deteriorate under adverse conditions.

<i>Part No.</i>	<i>Description and Contents</i>							
<b>Brake Lining</b>								
CP38/DMI	...	2	...	...	NW243/DMI	...	...	Lining, brake
		16	...	...	W129	...	...	Rivet
<b>Crankcase Bearings</b>								
CPI69	...	1	...	...	E3790	...	...	Bearing, R.H. main
		1	...	...	E3835	...	...	Bearing, L.H. main (Ball Journal)
<b>Fork Service Pack</b>								
CPI68	...	2	...	...	H441	...	...	Bearing, upper
		2	...	...	H443	...	...	Bearing, lower
		4	...	...	H430	...	...	Washer, fibre
		2	...	...	H1062	...	...	Washer, aluminium
		2	...	...	H420	...	...	Washer, felt
		2	...	...	H1168	...	...	Seal, oil
<b>Piston Assemblies (350 c.c.)</b>								
CPI64	...	1	...	...	E3689	...	...	Piston, standard
		1	...	...	E3691	...	...	Ring, top (plain)
		1	...	...	E3690	...	...	Ring, middle (taper)
		1	...	...	E3692	...	...	Ring, bottom (scraper)
		1	...	...	E1750	...	...	Pin, gudgeon
		2	...	...	E1767	...	...	Circlip
CPI64/10	...	1	...	...	E3689/10	...	...	Piston, + .010"
		1	...	...	E3691/10	...	...	Ring, top (plain)
		1	...	...	E3690/10	...	...	Ring, middle (taper)
		1	...	...	E3692/10	...	...	Ring, bottom (scraper)
		1	...	...	E1750	...	...	Pin, gudgeon
		2	...	...	E1767	...	...	Circlip
CPI64/20	...	1	...	...	E3689/20	...	...	Piston, ... .020"
		1	...	...	E3691/20	...	...	Ring, top (plain)
		1	...	...	E3690/20	...	...	Ring, middle (taper)
		1	...	...	E3692/20	...	...	Ring bottom (scraper)
		1	...	...	E1750	...	...	Pin, gudgeon
		2	...	...	E1767	...	...	Circlip

## GROUP I — CARTON PACK

Part No.

Description and Contents

### Piston Assemblies (350 c.c.)

CPI64/40	...	1	...	...	E3689/40	...	...	Piston, $\pm .040"$
		1	...	...	E3691/40	...	...	Ring, top (plain)
		1	...	...	E3690/40	...	...	Ring, middle (taper)
		1	...	...	E3692/40	...	...	Ring, bottom (scraper)
		1	...	...	E1750	...	...	Pin, gudgeon
		2	...	...	E1767	...	...	Circlip

### Piston Rings (350 c.c.)

CPI65	...	2	...	...	E3691	...	...	Ring, top (plain)
		2	...	...	E3690	...	...	Ring, middle (taper)
		2	...	...	E3692	...	...	Ring, bottom (scraper)
CPI65/10	...	2	...	...	E3691/10	...	...	Ring, top (plain)
		2	...	...	E3690/10	...	...	Ring, middle (taper)
		2	...	...	E3692/10	...	...	Ring, bottom (scraper)
CPI65/20	...	2	...	...	E3691/20	...	...	Ring, top (plain)
		2	...	...	E3690/20	...	...	Ring, middle (taper)
		2	...	...	E3692/20	...	...	Ring, bottom (scraper)
CPI65/40	...	2	...	...	E3691/40	...	...	Ring, top (plain)
		2	...	...	E3690/40	...	...	Ring, middle (taper)
		2	...	...	E3692/40	...	...	Ring, bottom (scraper)

### Steering Races

CPI67	...	1	...	...	H1110	...	...	Cone
		1	...	...	H1140	...	...	Cone and dust cover
		2	...	...	H1130	...	...	Cup
		48	...	...	S70-4	...	...	Balls

### Valves (350 c.c.)

CPI66	...	2	...	...	E3738	...	...	Valve, inlet
		2	...	...	E3739	...	...	Valve, exhaust

### Valve Guides

CPI70	...	4	...	...	E3208	...	...	Guide, valve inlet and exhaust
		4	...	...	E3209	...	...	Circlip, valve guide

### Valve Springs (350 c.c.)

CPI71	...	4	...	...	E3741	...	...	Spring, valve outer
		4	...	...	E3942	...	...	Spring, valve inner

## CARTON PACK—GROUP I

Part No.

Description and Contents

### Piston Assemblies (500 c.c.)

CPI74	...	...	1	...	...	E4004	...	...	...	Piston, standard
			1	...	...	E3829	...	...	...	Ring, top (plain)
			1	...	...	E3830	...	...	...	Ring, middle (taper)
			1	...	...	E3831	...	...	...	Ring, bottom (scraper)
			1	...	...	WE203E	...	...	...	Gudgeon pin
			2	...	...	WE479	...	...	...	Circlip
CPI74/10	...	...	1	...	...	E4004/10	...	...	...	Piston, + .010"
			1	...	...	E3829/10	...	...	...	Ring, top (plain)
			1	...	...	E3830/10	...	...	...	Ring, middle (taper)
			1	...	...	E3831/10	...	...	...	Ring, bottom (scraper)
			1	...	...	WE203E	...	...	...	Gudgeon pin
			2	...	...	WE479	...	...	...	Circlip
CPI74/20	...	...	1	...	...	E4004/20	...	...	...	Piston, + 0.020"
			1	...	...	E3829/20	...	...	...	Ring, top (plain)
			1	...	...	E3830/20	...	...	...	Ring, middle (taper)
			1	...	...	E3831/20	...	...	...	Ring, bottom (scraper)
			1	...	...	WE203E	...	...	...	Gudgeon pin
			2	...	...	WE479	...	...	...	Circlip

### Piston Rings (500 c.c.)

CPI75	...	...	2	...	...	E3829	...	...	...	Ring, top (plain)
			2	...	...	E3830	...	...	...	Ring, middle (taper)
			2	...	...	E3831	...	...	...	Ring, bottom (scraper)
CPI75/10	...	...	2	...	...	E3829/10	...	...	...	Ring, top (plain)
			2	...	...	E3830/10	...	...	...	Ring, middle (taper)
			2	...	...	E3831/10	...	...	...	Ring, bottom (scraper)
CPI75/20	...	...	2	...	...	E3829/20	...	...	...	Ring, top (plain)
			2	...	...	E3830/20	...	...	...	Ring, middle (taper)
			2	...	...	E3831/20	...	...	...	Ring, bottom (scraper)

### Valves (500 c.c.)

CPI76	...	...	2	...	...	E4012	...	...	...	Valve, inlet
			2	...	...	E4013	...	...	...	Valve, exhaust

### Valve Springs (500 c.c.)

CPI77	...	...	4	...	...	E4010	...	...	...	Spring, valve inner
			4	...	...	E4011	...	...	...	Spring, valve outer

### **PLEASE NOTE**

THROUGHOUT THIS LIST, ASSEMBLIES ARE PRINTED IN CAPITALS AND THE COMPONENTS INCLUDED IN THAT ASSEMBLY ARE INDENTED IN THE DESCRIPTION COLUMN, REVERTING TO THE ORIGINAL ALIGNMENT WHEN THE ASSEMBLY IS COMPLETE. TO ORDER THE COMPLETE ASSEMBLY IT IS NECESSARY ONLY TO QUOTE THE ASSEMBLY NUMBER. ANY COMPONENT PARTS LISTED MAY ALSO BE OBTAINED SEPARATELY, IF REQUIRED.



## REPLACEMENT PARTS

REF. No.	PART No.	DESCRIPTION	QUANTITY
----------	----------	-------------	----------

## ENGINE—GROUP 2

## CYLINDER BLOCK

			3TA	5TA
1	E3698	Block, cylinder ... ..	1	—
2	E4000	Block, cylinder ... ..	—	1
3	E3798	Washer, cylinder base ... ..	1	1
4	E2412	Nut, cylinder base ... ..	8	8

## PISTONS

5	CP164	PISTON COMPLETE ... ..	2	—
6	E3691	Ring (plain) ... ..	2	—
7	E3690	Ring, middle (taper) ... ..	2	—
8	E3692	Ring (scraper) ... ..	2	—
9	E1750	Pin, gudgeon ... ..	2	—
10	E1767	Circlip ... ..	4	—
11	CP174	PISTON COMPLETE ... ..	—	2
12	E3829	Ring (plain) ... ..	—	2
13	E3830	Ring, middle (taper) ... ..	—	2
14	E3831	Ring (scraper) ... ..	—	2
15	WE203E	Pin, gudgeon ... ..	—	2
16	WE479	Circlip ... ..	—	4

For oversizes see Pages 5-7

## CYLINDER HEAD AND VALVE GUIDES

17	E4017	HEAD, CYLINDER c/w GUIDES ... ..	1	—
18	E4007	HEAD, CYLINDER c/w GUIDES ... ..	—	1
19	E3208	Guide, valve ... ..	4	4
20	E3209	Circlip, valve guides ... ..	4	4
21	E2961	Adaptor, exhaust pipe ... ..	2	2
22	E3769	Gasket, cylinder head ... ..	1	—
23	E4015	Gasket, cylinder head ... ..	—	1
24	E3793	Bolt, cylinder head, 2 $\frac{1}{8}$ " U.H. ... ..	4	4
25	E3794	Bolt, cylinder head, 5 $\frac{7}{16}$ " U.H. ... ..	2	2
26	E3795	Bolt, cylinder head and torque stay, 5 $\frac{1}{16}$ " U.H. ... ..	2	2
27	F2184	Washer, head bolts ... ..	8	8

## GROUP 2 — ENGINE

REF. No.	PART No.	DESCRIPTION	QUANTITY	
<b>INLET MANIFOLD</b>				
			3TA	5TA
1	E4014	Manifold, inlet ... ..	1	1
2	E2967	Washer, manifold joint ... ..	2	2
3	E3796	Stud, manifold to head, $1\frac{17}{32}$ " O.A. ... ..	2	2
4	E3797	Stud, manifold to head, 2" O.A. ... ..	2	2
5	S25-13	Washer, manifold nut ... ..	4	4
6	W103	Nut, manifold stud ... ..	4	4
7	E3880	Stud, carburetter fixing, $1\frac{1}{4}$ " O.A. ... ..	2	2
8	NA43	Washer, carburetter joint ... ..	1	1
9	E3834	Block, insulating ... ..	1	1
10	244/765	"O" ring, carburetter to manifold ... ..	1	1
11	S25-3	Washer, carburetter nut ... ..	2	2
12	SI-51	Nut, carburetter to manifold ... ..	2	2
<b>VALVES AND SPRINGS</b>				
13	E3738	Valve, inlet ... ..	2	—
14	E3739	Valve, exhaust ... ..	2	—
15	E4012	Valve, inlet ... ..	—	2
16	E4013	Valve, exhaust ... ..	—	2
17	E3740	Cup, spring bottom ... ..	4	4
18	E3942	Spring, inner ... ..	4	—
19	E3741	Spring, outer ... ..	4	—
20	E4010	Spring, inner ... ..	—	4
21	E4011	Spring, outer ... ..	—	4
22	E3742	Collar, spring top ... ..	4	4
23	WE259A	Split cotter, valve ... ..	8	8
<b>ROCKER BOXES AND ROCKER GEAR</b>				
24	E3744	Box, exhaust rocker ... ..	1	1
25	E3745	Box, inlet rocker ... ..	1	1
26	E3743	Washer, rocker box joint ... ..	2	2
27	E3752	Cap, inspection ... ..	4	4
28	E3751	Washer, cap joint ... ..	4	4
29	E3858	Stud, to head, $\frac{5}{16}$ " O.A. ... ..	4	4
30	E3302	Washer, stud nut ... ..	4	4
31	F879	Nut, rocker box stud ... ..	4	4
32	E3668	Screw, to head $\frac{3}{16}$ " U.H. ... ..	4	4
33	E3857	Washer screw ... ..	4	4

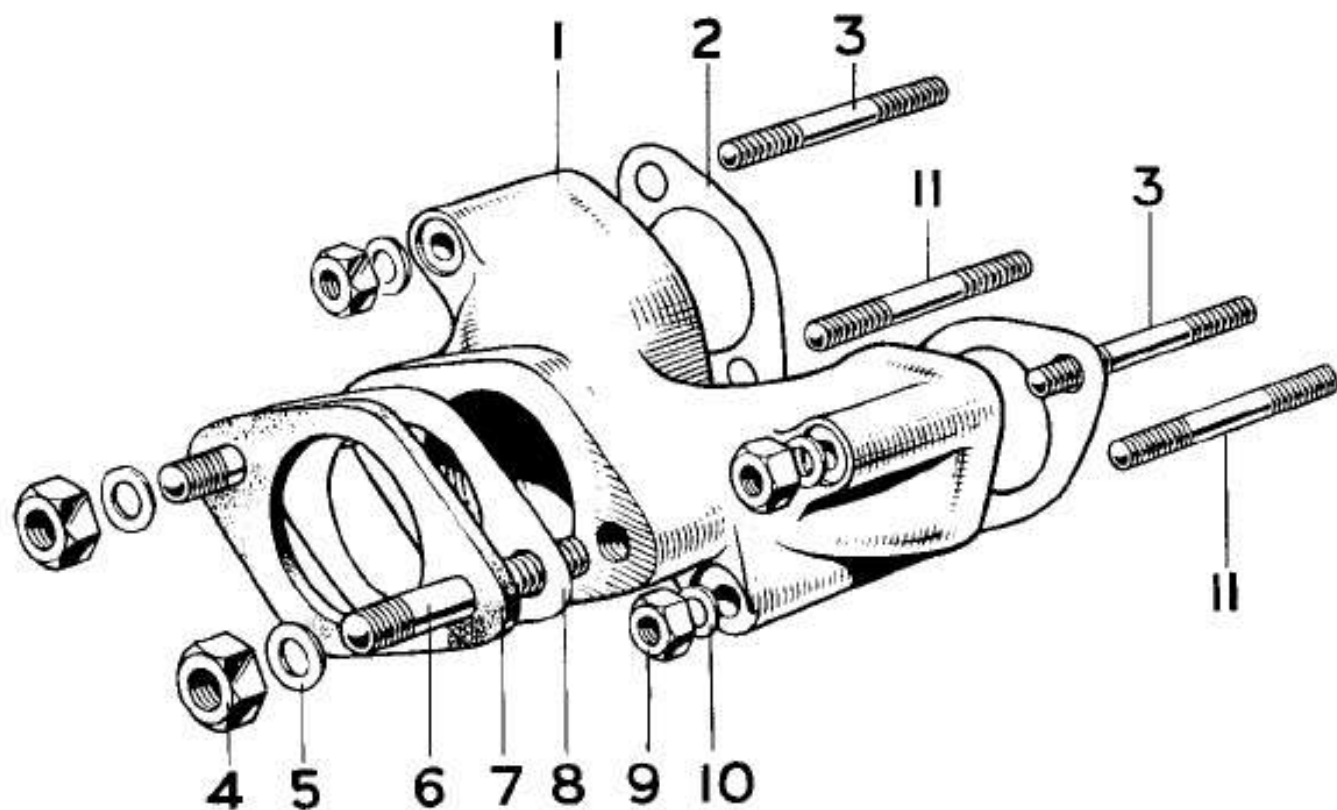

FIG. 1 INLET MANIFOLD

INDEX TO FIG. 1

<i>Illust. No.</i>	<i>Part No.</i>	<i>Page No.</i>	<i>Ref. No.</i>
1	E4014	10	1
2	E2967	10	2
3	E3796	10	3
4	S1-51	10	12
5	S25-3	10	11
6	E3880	10	7
7	E3834	10	9
8	NA43	10	8
9	W103	10	6
10	S25-13	10	5
11	E3797	10	4

## GROUP 2 — ENGINE

REF. No.	PART No.	DESCRIPTION	QUANTITY	
			3TA	5TA
1	E3748	Spindle, rocker ... ..	2	2
2	E3253	Sealing ring, rocker spindle ... ..	2	2
3	E3749	LEVER, ROCKER, R.H. EXHAUST, L.H. INLET	2	2
4	E3750	LEVER, ROCKER, L.H. EXHAUST, R.H. INLET	2	2
5	E3222	Ball pin ... ..	4	4
6	E3223	Adjuster, rocker ... ..	4	4
7	GS662	Nut, adjuster lock ... ..	4	4
8	E3224	Washer, Thackeray (spring) ... ..	4	4
9	E2534	Washer, thrust ( $\frac{7}{16}$ " I.D.) ... ..	6	6
10	E1330	Washer, thrust ( $\frac{3}{8}$ " I.D.) ... ..	2	2
11	E1335	Washer, copper ... ..	2	2
12	E1435	Nut, rocker spindle ... ..	2	2
<b>ROCKER OIL FEED PIPE</b>				
13	E3809	Bolt, oil feed hollow ... ..	2	2
14	F1880	Washer, copper ... ..	6	6
15	H400	Nut, domed ... ..	2	2
16	E3805	Pipe, rocker oil feed ... ..	1	1
<b>CRANKSHAFT</b>				
17	E3996	FLYWHEEL AND CRANKSHAFT ASSEMBLY ...	1	1
18	E3998	Crankshaft ... ..	1	1
19	E3999	Tube, crankshaft oil ... ..	1	1
20	E3711	Plug, crankshaft R.H. ... ..	1	1
21	E3712	Flywheel ... ..	1	1
22	E2288	Washer, shakeproof ... ..	3	3
23	E3713	Bolt, flywheel to crankshaft ... ..	3	3
<b>CONNECTING RODS</b>				
24	E3702	ROD, CONNECTING ... ..	2	-
25	E1762	Bush, small end ... ..	2	-
26	E3705	Bolt, rod to cap ... ..	4	-
27	E2922	Nut, cap bolt ... ..	4	-
28	E4001	ROD, CONNECTING ... ..	-	2
29	E4003	Bush, small end ... ..	-	2
30	E3705	Bolt, rod to cap ... ..	-	4
31	E2922	Nut, cap bolt ... ..	-	4
32	E3706	Bearing, big end standard ... ..	4	4
33	E3706/10	Bearing, big end, 0.010" undersize ... ..	A	A
32	E3706/20	Bearing, big end, 0.020" undersize ... ..	A	A
34	E3706/30	Bearing, big end, 0.030" undersize ... ..	A	A

# ENGINE — GROUP 2

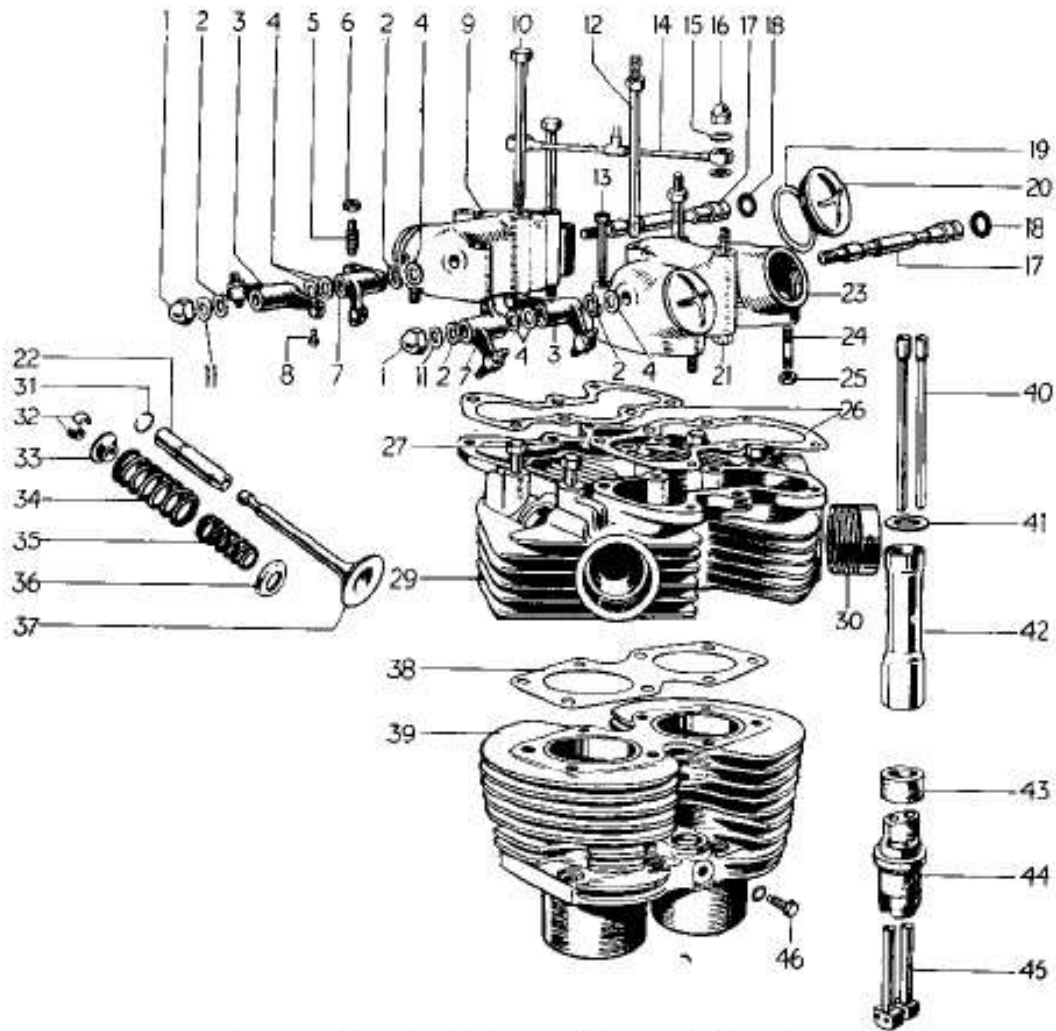

**FIG. 2 CYLINDER BLOCK AND HEAD, 3TA.  
INDEX TO FIG. 2**

Illust. No.	Part No.	Page No.	Ref. No.	Illust. No.	Part No.	Page No.	Ref. No.
1	E1435	12	12	24	E3858	10	29
2	E3224	12	8	25	F879	10	31
3	E3750	12	4	26	E3743	10	26
4	E2534	12	9	27	E3793	9	24
5	E3223	12	6	29	E4007	9	18
6	GS662	12	7	30	E2961	9	21
7	E3749	12	3	31	E3209	9	20
8	E3222	12	5	32	WE259A	10	23
9	E3745	10	25	33	E3742	10	22
10	E3794	9	25	34	E4011	10	21
11	E1330	12	10	35	E4010	10	20
12	E3795	9	26	36	E3740	10	17
13	E3668	10	32	37	E4012	10	15
14	E3805	12	16		E4013	10	16
15	F1880	12	14	38	E4015	9	23
16	H400	12	15	39	E4000	9	2
17	E3748	12	1	40	E3759	19	20
18	E3253	12	2	41	E3547	19	23
19	E3751	10	28	42	E3755	19	22
20	E3752	10	27	43	E3758	19	24
21	E3809	12	13	44	E3736	19	16
22	E3208	9	19	45	E3753	19	19
23	E3744	10	24	46	H200	19	17

## GROUP 2 — ENGINE

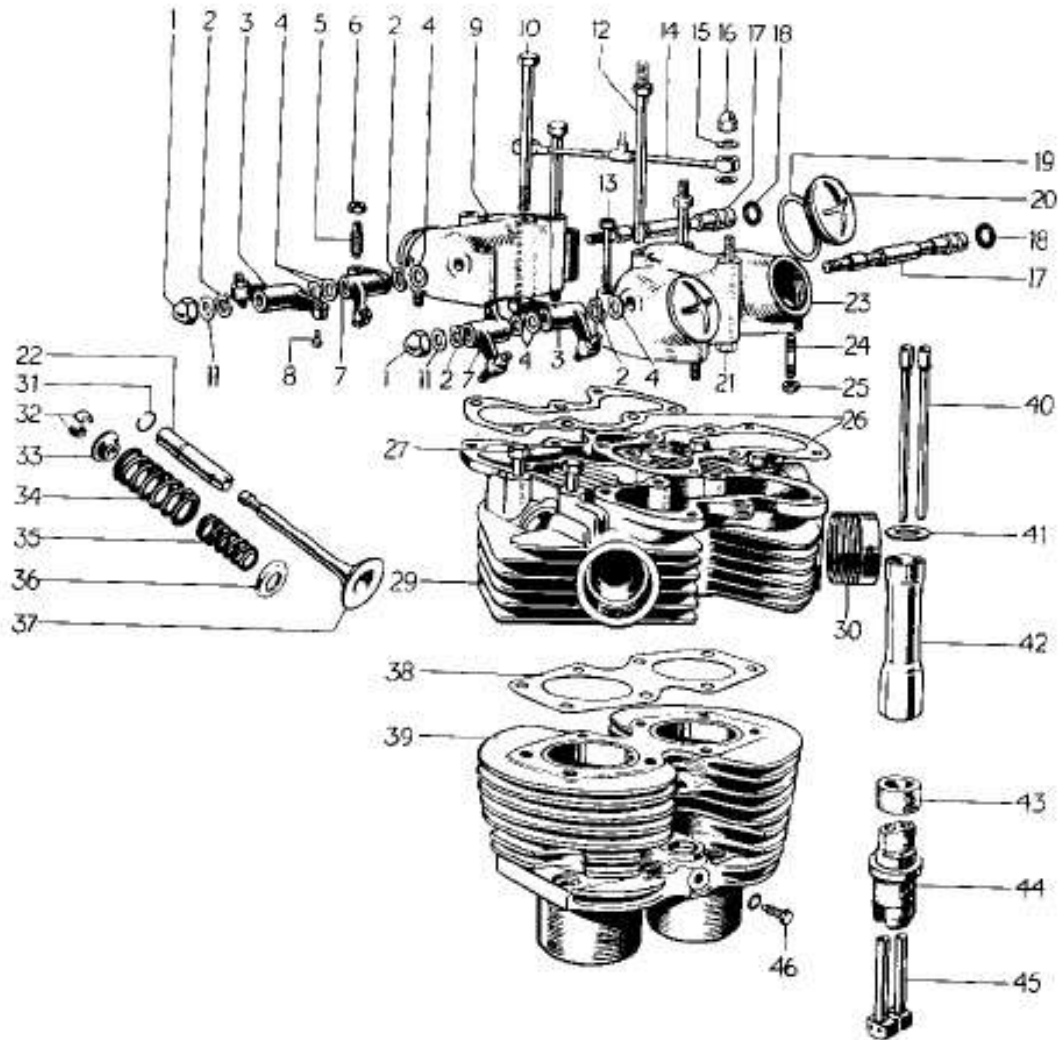
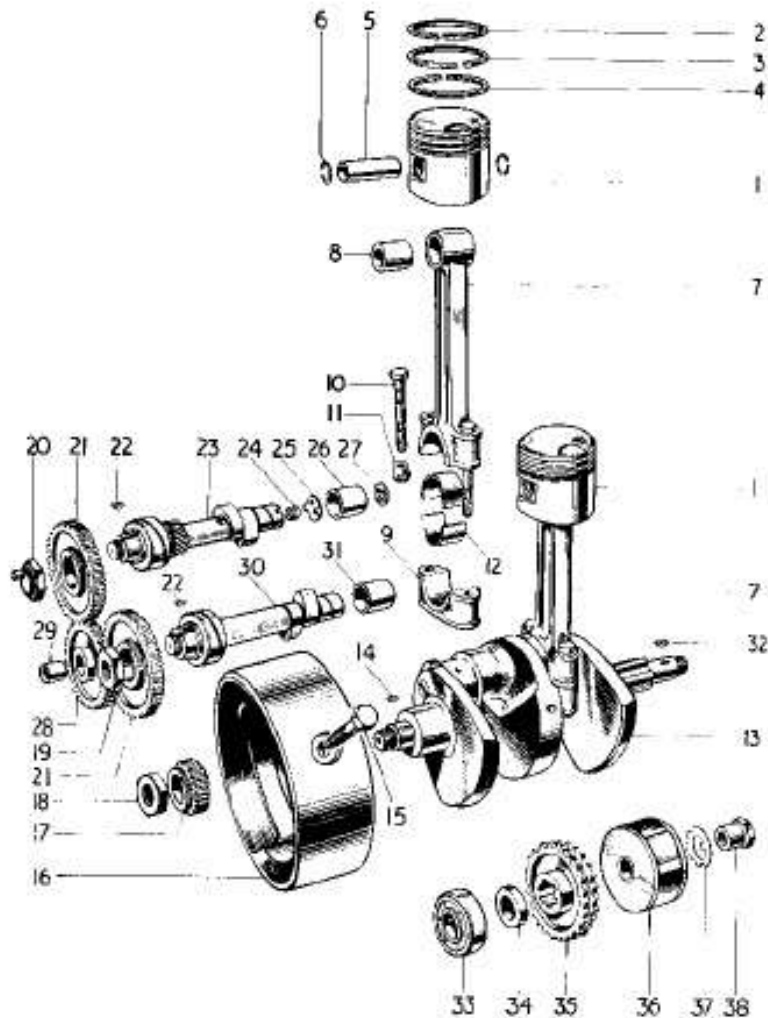

FIG. 3 CYLINDER BLOCK AND HEAD, 5TA  
INDEX TO FIG. 3

Illust. No.	Part No.	Page No.	Ref. No.	Illust. No.	Part No.	Page No.	Ref. No.
1	E1435	12	12	24	E3858	10	29
2	E3224	12	8	25	F879	10	31
3	E3750	12	4	26	E3743	10	26
4	E2534	12	9	27	E3793	9	24
5	E3223	12	6	29	E4017	9	17
6	GS662	12	7	30	E3961	9	21
7	E3749	12	3	31	E3209	9	20
8	E3222	12	5	32	WE259A	10	23
9	E3745	10	25	33	E3742	10	22
10	E3794	9	25	34	E3741	10	19
11	E1330	12	10	35	E3942	10	18
12	E3795	9	26	36	E3740	10	17
13	E3668	10	32	37	E3738	10	13
14	E3805	12	16	38	E3739	10	14
15	F1880	12	14	39	E3769	9	22
16	H400	12	15	40	E3698	9	1
17	E3748	12	1	41	E3759	19	20
18	E3253	12	2	42	E3547	19	23
19	E3751	10	28	43	E3755	19	22
20	E3752	10	27	44	E3758	19	24
21	E3809	12	13	45	E3736	19	16
22	E3208	9	19	46	E3753	19	19
23	E3744	10	24		H200	19	17

## ENGINE — GROUP 2



**FIG. 4 CRANKSHAFT AND CONNECTING RODS  
INDEX TO FIG. 4**

Illust. No.	Part No.	Page No.	Ref. No.	Illust. No.	Part No.	Page No.	Ref. No.
1	CP164	9	5	17	E1771	19	1
	CP174	9	11	18	E398	19	3
2	E3691	9	6	19	E1492	19	9
	E3829	9	12	20	E1463	19	8
3	E3690	9	7	21	E1486A	19	6
	E3830	9	13	22	E1558	19	7
4	E3692	9	8	23	E3838	19	10
	E3831	9	14	24	E2256	17	39
5	E1750	9	9	25	E2254	17	38
	WE203E	9	15	26	E3824	16	19
6	E1767	9	10	27	E3822	16	18
	WE479	9	16	28	E2202	19	4
7	E3702	12	24	29	E440	19	5
	E4001	12	28	30	E3839	19	11
8	E1762	12	25	31	E3823	10	21
	E4003	12	29	32	E3851	59	2
9	Not serviced separately			33	E3835	16	31
10	E3705	12	26	34	E4006	20	17
11	E2922	12	27	35	E3734	20	18
13	E3998	12	19	36	423506	59	1
14	E1580	19	2	37	E3852	20	19
15	E3713	12	23	38	E3735	20	20
16	E3712	12	21				

## GROUP 2 — ENGINE

REF. No.	PART No.	DESCRIPTION	QUANTITY	
<b>CRANKCASE</b>				
			3TA	5TA
1	E3688/4005	CRANKCASE C/W STUDS AND R.H. MAIN BEARING ... ..		
2	E3716	Dowel, hollow crankcase halves ... ..	1	1
3	E3717	Stud, oil pipes junction, 1½" O.A. ... ..	1	1
4	E3718	Stud, oil pump, 1- <sup>5</sup> / <sub>16</sub> " O.A. ... ..	2	2
5	E3820	Stud, cylinder base, 1½" O.A. ... ..	6	6
6	E3819	Stud, cylinder base (dowels), 1- <sup>11</sup> / <sub>16</sub> " O.A. ... ..	2	2
7	E1534A	Dowel, cylinder base ... ..	2	2
8	E3859	Screw, at camshaft bosses, <sup>21</sup> / <sub>32</sub> " U.H. ... ..	2	2
9	E3803	Stud, rear, crankcase halves, 3 <sup>1</sup> / <sub>4</sub> " O.A. ... ..	2	2
10	E3804	Stud, bottom front, 3" O.A. ... ..	1	1
11	E3799	Bolt, top rear, 1½" U.H. ... ..	1	1
12	S25-3	Washer, studs and bolts ... ..	5	5
13	S1-51	Nut, front and rear studs ... ..	4	4
14	E3719	Pipe, oil scavenge ... ..	1	1
15	E1509	Clip, scavenge pipe ... ..	1	1
16	E1645	Screw, clip, 1½" U.H. ... ..	1	1
17	E3172	Pin, breather disc ... ..	1	1
18	E3822	Disc, breather ... ..	1	1
19	E3824	Bush, inlet camshaft (breather) ... ..	1	1
20	E3877	Bush, distributor shaft ... ..	1	1
21	E3823	Bush, exhaust camshaft ... ..	1	1
22	E2724	Pipe, breather (steel) ... ..	1	1
23	E375	Spindle, intermediate timing gear ... ..	1	1
24	E3885	Jet, chain oiler ... ..	1	1
25	E3884	Tube, chain oiler ... ..	1	1
26	T912	Peg, R.H., main bearing ... ..	1	1
27	E3790	Bearing, R.H. main, standard ... ..	1	1
28	E3790/10	Bearing, R.H. main, 0.010" undersize ... ..	A	A
29	E3790/20	Bearing, R.H. main, 0.020" undersize ... ..	A	A
30	E3790/30	Bearing, R.H. main, 0.030" undersize ... ..	A	A
<b>CRANKCASE BEARINGS</b>				
31	E3835	Bearing, L.H. ball journal ... ..	1	1
32	E3876	Oil seal, L.H. bearing ... ..	1	1



## ENGINE—GROUP 2

REF. No.	PART No.	DESCRIPTION	QUANTITY	
			3TA	5TA
<b>CRANKCASE FITTINGS</b>				
33	E3724	Spring, crankcase filter ... ..		
34	E3722	Filter, crankcase scavenge ... ..		
35	E3723	Washer, filter sealing ... ..		
36	E1564	Cap, crankcase filter ... ..		
37	E1577	Washer, cap joint ... ..		
38	E2254	Valve, rotary breather ... ..		
39	E2256	Spring, breather valve ... ..		
40	E3078	Pipe, breather extension (P.V.C.) ... ..		

### PLEASE NOTE

THROUGHOUT THIS LIST, ASSEMBLIES ARE PRINTED IN CAPITALS AND THE COMPONENTS INCLUDED IN THAT ASSEMBLY ARE INDENTED IN THE DESCRIPTION COLUMN, REVERTING TO THE ORIGINAL ALIGNMENT WHEN THE ASSEMBLY IS COMPLETE. TO ORDER THE COMPLETE ASSEMBLY IT IS NECESSARY ONLY TO QUOTE THE ASSEMBLY NUMBER. ANY COMPONENT PARTS LISTED MAY ALSO BE OBTAINED SEPARATELY, IF REQUIRED.

# GROUP 2 — ENGINE

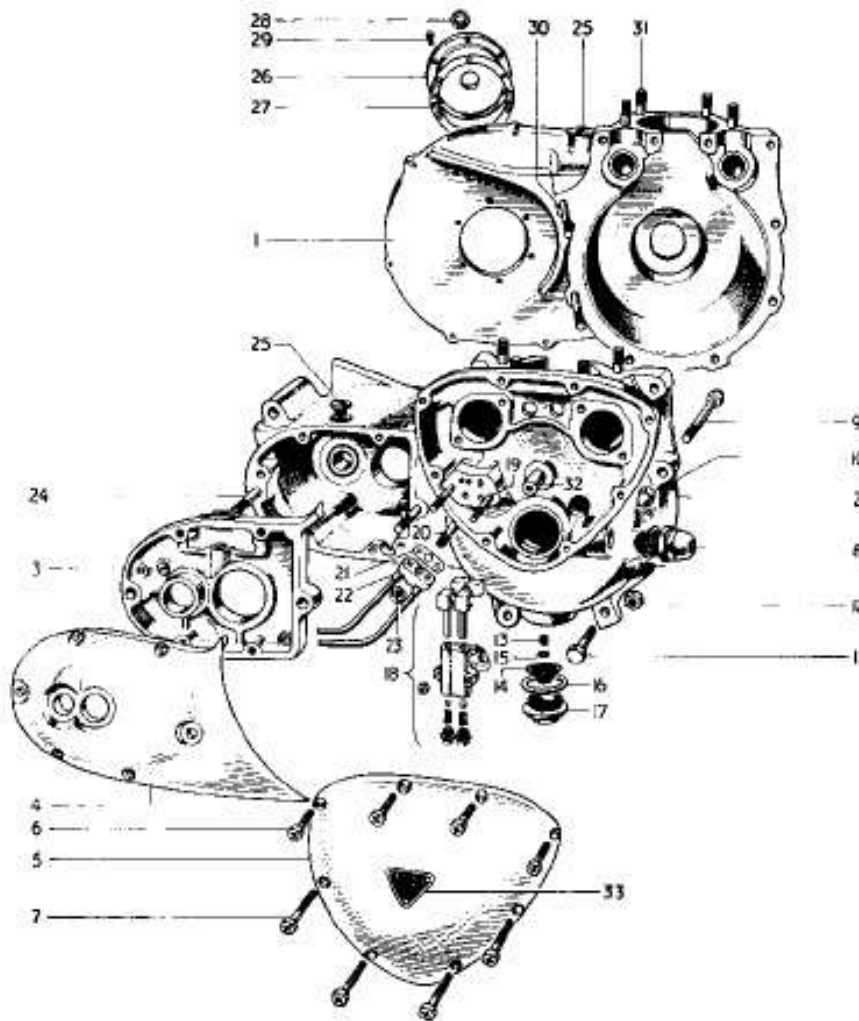

FIG. 5 CRANKCASE AND COVERS

## INDEX TO FIG. 5

Illust. No.	Part No.	Page No.	Ref. No.	Illust. No.	Part No.	Page No.	Ref. No.
1	E3688/4005	16	1	18	E3878	19	25
2				19	E3718	16	4
3	T1448	24	9	20	E3717	16	3
4	T1450	24	24	21	E3763	48	16
5	E3693	20	1	22	E3853	48	15
6	E3800	20	4	23	E1310	48	17
7	E3801	20	5	24	T1399	22	22
8	E2795	20	6	25	E732	29	16
9	E3937	30	12	26	E3789	26	28
10	H400	30	14	27	E3832	26	29
11	E3804	16	10	28	E3833	26	30
12	S1-51	16	13	29	E3821	26	31
13	E3724	16	33	30	E3803	16	9
14	E3722	17	34	31	E3820	16	5
15	E3723	17	35	32	E375	16	23
16	E1577	17	37	33	E4016	20	2
17	E1564	17	36				

## ENGINE — GROUP 2

REF. No.	PART No.	DESCRIPTION	3TA	5TA
<b>TIMING GEARS AND CAMSHAFTS</b>				
1	E1771	Pinion, timing	1	1
2	E1580	Key, timing pinion	1	1
3	E398	Nut, timing pinion	1	1
4	E2202	WHEEL, INTERMEDIATE TIMING	1	1
5	E440	Bush, intermediate wheel	1	1
6	E1486A	Pinion, camshaft	2	2
7	E1558	Key, camshaft pinion	2	2
8	E1463	Nut, inlet camshaft (oil pump drive)	1	1
9	E1492	Nut, exhaust camshaft	1	1
10	E3838	Camshaft, inlet	1	1
11	E3839	Camshaft, exhaust	1	1
12	E3727	Plate, camshaft retaining	2	2
13	E3728	Screw, retaining plate, $\frac{1}{32}$ " U.H.	4	4
14	E3729	Pinion, distributor drive	1	1
15	404314	Pin, distributor pinion	1	1
<b>TAPPETS AND PUSH RODS</b>				
16	E3736	Block, tappet guide	2	2
17	H200	Bolt, lock	2	2
18	E2312	Washer, shakeproof	2	2
19	E3753	Tappet	4	4
20	E3759	Rod, valve push	4	—
21	E4008	Rod, valve push	—	4
22	E3755	Tube, push rod cover	2	2
23	E3547	Washer, cover tube top	2	2
24	E3758	Washer, cover tube bottom	2	2
<b>OIL PUMP</b>				
25	E3878	PUMP, OIL	1	1
26	E3731	Body, oil pump	1	1
27	S70-7	Ball, valve	2	2
28	E403	Spring, valve	2	2
29	E2360	Plug, body	2	2
30	GS153	Plunger, feed	1	1
31	E1476	Plunger scavenge	1	1
32	E495	Block, pump drive	1	1
33	E3730	Washer, pump to crankcase	1	1
34	E3732	Nut, pump to crankcase	2	2
35	E3887	Washer, pump nut	2	2

## GROUP 2 — ENGINE

REF. No.	PART No.	DESCRIPTION	3TA	5TA
<b>TIMING COVER</b>				
1	E3693	COVER, TIMING GEARS ... ..	1	1
2	E4016	Plate, patent number ... ..	1	1
3	D208-5	Screw, hammer drive ... ..	3	3
4	E3800	Screw, short, $\frac{7}{8}$ " U.H. ... ..	4	4
5	E3801	Screw, long, $1\frac{1}{8}$ " U.H. ... ..	4	4
<b>OIL PRESSURE RELEASE VALVE</b>				
6	E2795	VALVE, OIL PRESSURE RELEASE ... ..	1	1
7	E2794	Body, release valve ... ..	1	1
8	GS254	Washer, cap to body ... ..	1	1
9	E2790	Cap, release valve ... ..	1	1
10	GS251	Piston, release valve ... ..	1	1
11	E2791	Shaft and button, release valve ... ..	1	1
12	E2792	Nut, shaft ... ..	1	1
13	E2793	Seal, rubber ... ..	1	1
14	E2788	Spring, main ... ..	1	1
15	E2789	Spring, auxillary ... ..	1	1
16	E1670	Washer, valve to crankcase ... ..	1	1
<b>ENGINE SPROCKET</b>				
17	E4006	Collar, distance (oil seal) ... ..	1	1
18	E3734	Sprocket, engine, 26T Duplex ... ..	1	1
19	E3852	Washer, tab ... ..	1	1
20	E3735	Nut, sprocket and rotor ... ..	1	1

See Page 59 for rotor and key

### **PLEASE NOTE**

THROUGHOUT THIS LIST, ASSEMBLIES ARE PRINTED IN CAPITALS AND THE COMPONENTS INCLUDED IN THAT ASSEMBLY ARE INDENTED IN THE DESCRIPTION COLUMN, REVERTING TO THE ORIGINAL ALIGNMENT WHEN THE ASSEMBLY IS COMPLETE. TO ORDER THE COMPLETE ASSEMBLY IT IS NECESSARY ONLY TO QUOTE THE ASSEMBLY NUMBER. ANY COMPONENT PARTS LISTED MAY ALSO BE OBTAINED SEPARATELY, IF REQUIRED.

## GROUP 3 — GEARBOX

REF. No.	PART No.	DESCRIPTION	3TA	5TA
<b>GEARBOX — GROUP 3</b>				
<b>SHAFTS AND GEARS</b>				
1	T1403	GEAR, MAINSHAFT HIGH (26T) ... ..		
2	T1405	Bush, mainshaft high gear ... ..		
3	T1406	MAINSHAFT, CLUSTER, THIRD AND LOW GEARS		
4	T1391	Bush, mainshaft for clutch rod ... ..		
5	T1410	Gear, mainshaft second (23T) ... ..		
6	T1411	Distance piece, mainshaft R.H. ... ..		
7	T1479	Layshaft cluster, second and high gears ... ..		
8	T1413	Gear, layshaft third (23T) ... ..		
9	T1414	GEAR, LAYSHAFT LOW (32T) ... ..		
10	T1393	Bush, layshaft low gear ... ..		
11	T1426	Disc, layshaft low gear ... ..		
<b>GEARBOX BEARINGS</b>				
12	T665	Bearing, ball journal L.H., high gear ... ..		
13	T1478	Seal, high gear oil ... ..		
14	W680	Circlip, seal and bearing ... ..		
15	T1367	Bush, layshaft L.H. ... ..		
16	T912	Peg, layshaft bush ... ..		
17	T981	Disc, layshaft bush ... ..		
18	T1469	Bearing, ball journal R.H. mainshaft ... ..		
19	T280	Circlip, bearing to inner cover ... ..		
20	T732	Washer, tab ... ..		
21	E2419	Nut, mainshaft R.H. ... ..		
<b>GEARBOX CASING FITTINGS</b>				
22	T1399	Stud, gearbox covers, $3\frac{1}{16}$ " O.A. ... ..	2	2
23	T1112	Plug, gearbox drain (with level tube) ... ..		
24	WE170	Washer, drain plug ... ..		
25	T361	Plug, gearbox level ... ..		
26	T1257	Washer, level plug ... ..		
27	E732	Plug, gearbox filler ... ..		
28	NE507	Washer, filler plug ... ..		
29	T1471	Plunger, camplate index ... ..		
30	T373	Spring, camplate plunger ... ..		
31	T1437	Plug, plunger housing ... ..		

## GEARBOX — GROUP 3

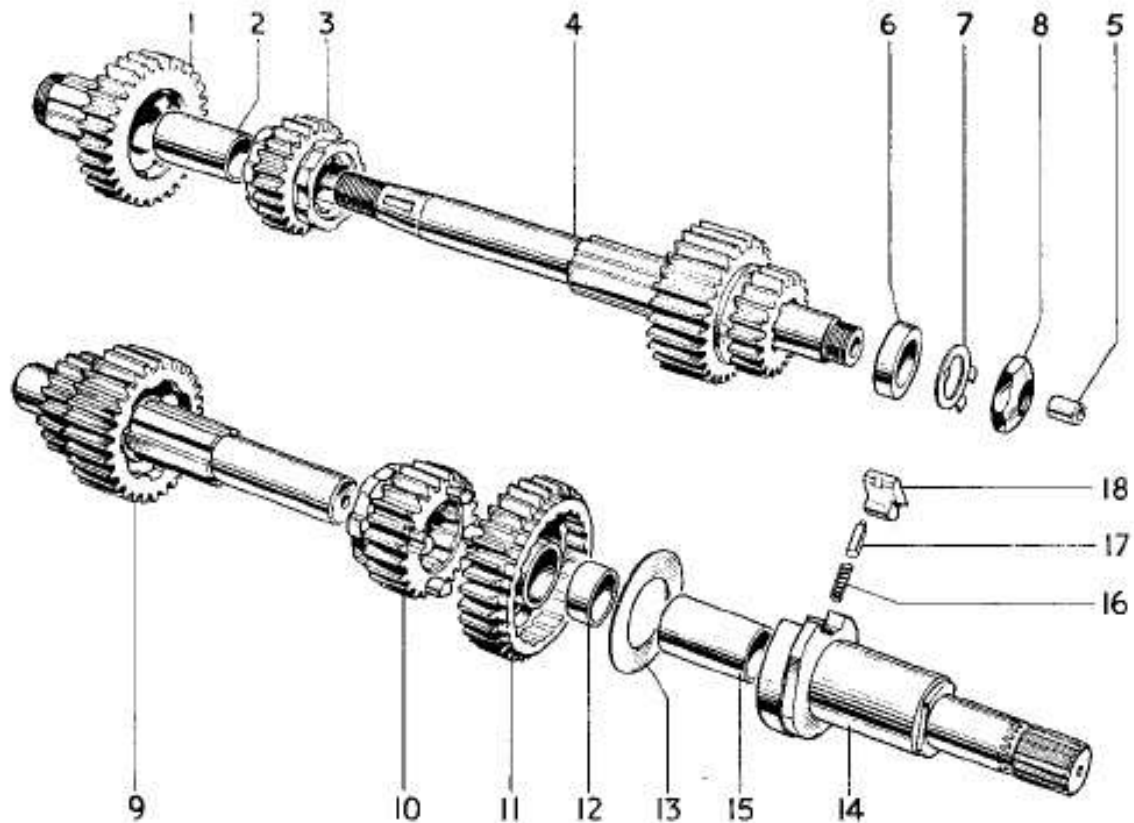

FIG. 6 SHAFTS AND GEARS

### INDEX TO FIG. 6

<i>Illust. No.</i>	<i>Part No.</i>	<i>Page No.</i>	<i>Ref. No.</i>
1	T1403	22	1
2	T1405	22	2
3	T1410	22	5
4	T1406	22	3
5	T1391	22	4
6	T1411	22	6
7	T732	22	20
8	E2419	22	21
9	T1479	22	7
10	T1413	22	8
11	T1414	22	9
12	T1393	22	10
13	T1426	22	11
14	T1445	24	13
15	T1446	24	17
16	T1161	24	16
17	T1282	24	15
18	T1431	24	14

## GROUP 3 — GEARBOX

REF. No.	PART No.	DESCRIPTION	3TA	5TA
<b>GEAR CHANGE MECHANISM</b>				
1	T1480	Fork, mainshaft selector ... ..	1	1
2	T1481	Fork, layshaft selector ... ..	1	1
3	T1457	Spindle, selector forks ... ..	1	1
4	T1458	Camplate, gear selector ... ..	1	1
5	T1418	Spindle, camplate ... ..	1	1
6	—	Split pin, spindle $\frac{1}{8}$ " x 1" ... ..	1	1
7	T1416	Finger, gear indicator ... ..	1	1
8	H688	Screw, finger to spindle, $\frac{1}{16}$ " U.H. ... ..	1	1
<b>INNER COVER AND KICKSTARTER</b>				
9	T1448	Cover, gearbox inner ... ..	1	1
10	T1417	Plate, gear positions ... ..	1	1
11	D208-5	Screw, hammer drive ... ..	2	2
12	T1440	Dowel, hollow ... ..	2	2
13	T1445	SPINDLE, KICKSTARTER ... ..	1	1
14	T1431	Pawl, kickstarter spindle ... ..	1	1
15	T1282	Plunger, kickstarter pawl ... ..	1	1
16	T1161	Spring, plunger ... ..	1	1
17	T1446	Bush, layshaft to spindle ... ..	1	1
18	T1157	Plate, kickstarter stop ... ..	1	1
19	T1390	Screw, stop plate and spring anchor ... ..	1	1
20	T1464	Distance piece, spindle ... ..	1	1
21	T1441	Spring, kickstarter return ... ..	1	1
22	T1422	Plate, return spring ... ..	1	1
23	E3204	Screw, inner cover to casing, 1" U.H. ... ..	2	2
<b>OUTER COVER AND CLUTCH LEVER</b>				
24	T1450	COVER, GEARBOX OUTER ... ..	1	1
25	T1395	Bush, gear change spindle ... ..	1	1
26	T1388	Stud, spring housing, $1\frac{1}{16}$ " O.A. ... ..	2	2
27	E1987	Stud, spring housing, $1\frac{1}{16}$ " O.A. ... ..	1	1
28	T1483	QUADRANT, GEARCHANGE ... ..	1	1
29	T1474	Pin, spring anchoring ... ..	2	2
30	T1436	Spring, plunger ... ..	2	2
31	T1396	Plunger, gear selector ... ..	2	2
32	—	Split pin, $\frac{3}{16}$ " x $\frac{3}{4}$ " ... ..	2	2
33	E3309	Sealing ring, rubber ... ..	1	1
34	T1484	LEVER AND WORM, CLUTCH OPERATING ... ..	1	1
35	S70-7	Ball, for clutch rod ... ..	1	1
36	T1462	Abutment, cable ... ..	1	1
37	E3302	Washer, cable abutment ... ..	1	1
38	—	Split pin, $\frac{1}{16}$ " x $\frac{3}{4}$ " ... ..	2	2



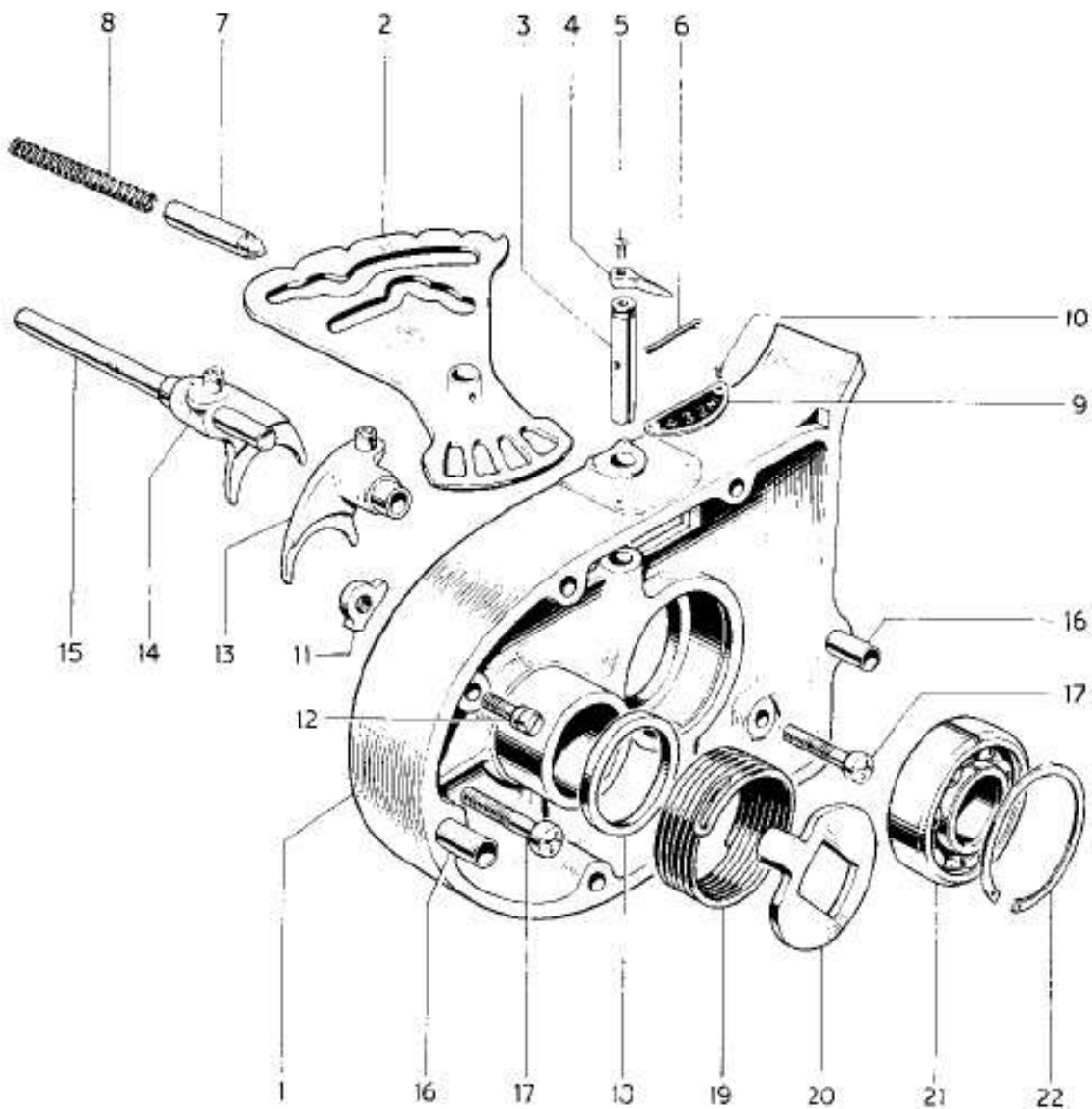

FIG. 7 GEARBOX INNER COVER

INDEX TO FIG. 7

Illust. No.	Part No.	Page No.	Ref. No.	Illust. No.	Part No.	Page No.	Ref. No.
1	T1448	24	9	12	T1390	24	19
2	T1458	24	4	13	T1481	24	2
3	T1457	24	3	14	T1480	24	1
4	T1416	24	7	15	T1457	24	3
5	H688	24	8	16	T1440	24	12
6	$\frac{1}{8}$ "x1" Split Pin	24	6	17	E3204	24	23
7	T1471	22	29	18	T1464	24	20
8	T373	22	30	19	T1441	24	21
9	T1417	24	10	20	T1422	24	22
10	D238-5	24	11	21	T1469	22	18
11	T1157	24	18	22	T280	22	19

## GROUP 3 — GEARBOX

REF. No.	PART No.	DESCRIPTION	3TA	5TA
1	T1385	Housing, quadrant return springs	1	1
2	T1432	Spring, quadrant return	2	2
3	T1433	Button, return spring	2	2
4	T1394	Cover, springs	1	1
5	S25-1	Washer, short stud	1	1
6	W103	Nut, housing to cover	3	3
7	T1465	Spring, clutch cable	1	1
8	E3475	Grommet, clutch cable	1	1
9	S1-51	Nut, cover to casing	2	2
10	S25-3	Washer	2	2
11	T1401	Screw, cover to casing, 2 $\frac{1}{8}$ " U.H.	2	2
12	T1402	Screw, cover to casing, 2 $\frac{1}{8}$ " U.H.	2	2
<b>GEARCHANGE AND KICKSTARTER LEVERS</b>				
13	T1435	Lever, gearchange	1	1
14	T449	Rubber, gearchange lever	1	1
15	W932	Bolt, gearchange lever, 1" U.H.	1	1
16	T1485	LEVER, KICKSTARTER FOLDING	1	1
17	T1438	Crank, kickstarter	1	1
18	T1272	Pedal, kickstarter	1	1
19	S70-3	Ball, pedal index	1	1
20	T1167	Spring, pedal index	1	1
21	T1273	Bolt, pedal pivot	1	1
22	T1439	Bolt, lever clamp, 1 $\frac{3}{16}$ " U.H.	1	1
23	F1814	Rubber, kickstarter lever	1	1
<b>GEARBOX SPROCKET AND COVER PLATE</b>				
24	T1476	Sprocket, gearbox (18 teeth)	1	-
25	T1558	Sprocket, gearbox (17 teeth)	A	A
26	T1569	Sprocket, gearbox (20 teeth)	-	1
27	T1434	Nut, gearbox sprocket	1	1
28	E3789	Plate, sprocket cover	1	1
29	E3832	Washer, cover plate joint	1	1
30	E3833	Seal, mainshaft oil	1	1
31	E3821	Screw, plate to crankcase, $\frac{5}{16}$ " U.H.	6	6
<b>CLUTCH AND SHOCK ABSORBER</b>				
32	T1486	CLUTCH COMPLETE	1	1
33	T1386	Hub, clutch to shaft	1	1
34	T394	Roller, sprocket to hub	1	1
35	T1442	Sprocket and housing	1	1
36	T1041	Spider, shock absorber	1	1
37	T1039	Plate, shock absorber, inner	1	1
38	T1037	Centre housing, clutch	1	1

# GEARBOX — GROUP 3

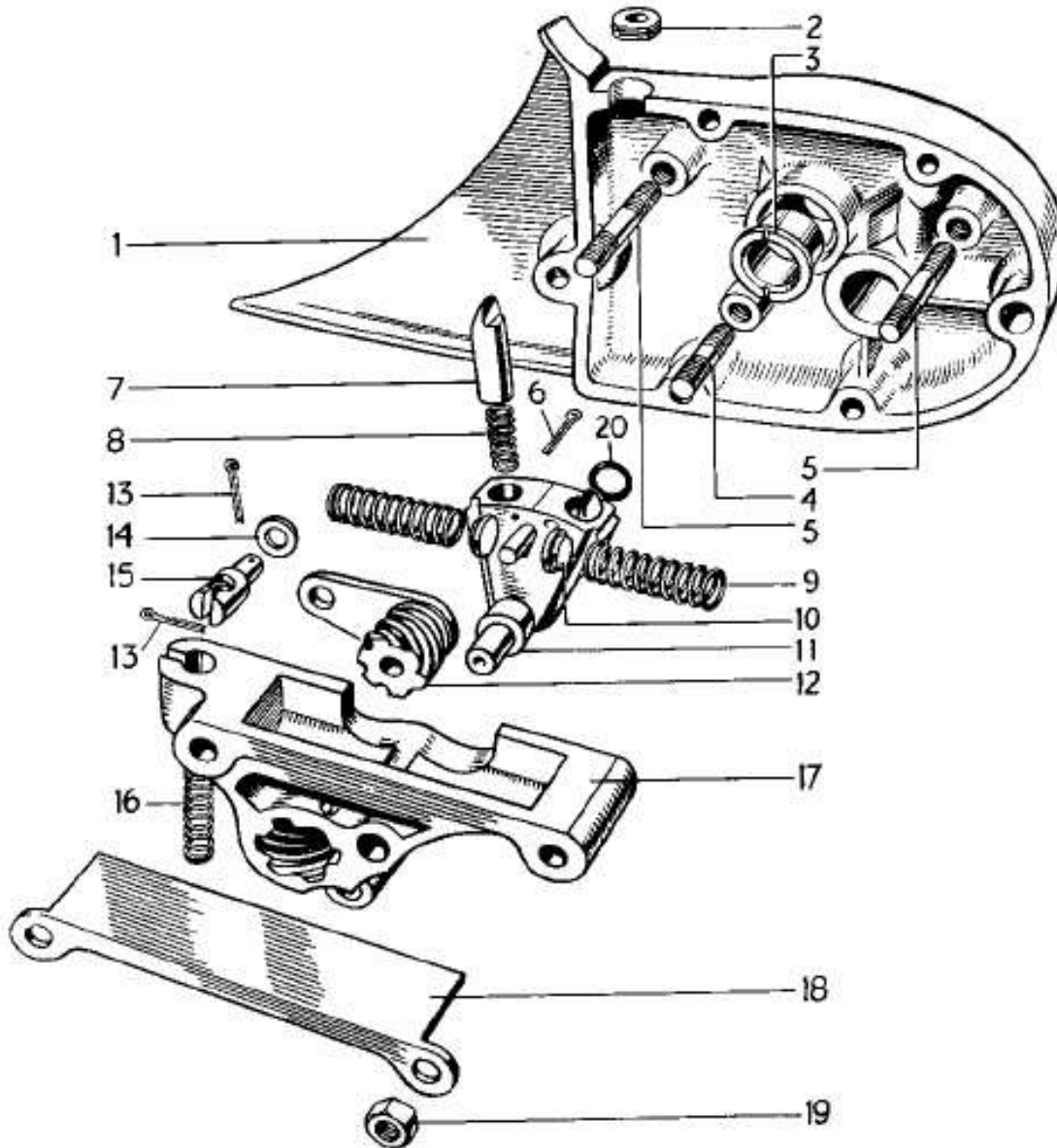

**FIG. 8**  
**GEARBOX OUTER COVER**

## INDEX TO FIG. 8

Illust. No.	Part No.	Page No.	Ref. No.	Illust. No.	Part No.	Page No.	Ref. No.
1	T1450	24	24	11	T1483	24	28
2	E3475	26	8	12	T1484	24	34
3	T1395	24	25	13	Split pin	24	38
4	E1987	24	27	14	E3302	24	37
5	T1388	24	26	15	T1462	24	36
6	Split pin	24	32	16	T1465	26	7
7	T1396	24	31	17	T1385	26	1
8	T1436	24	30	18	T1394	26	4
9	T1432	26	2	19	W103	26	6
10	T1433	26	3	20	E3309	24	33

## GROUP 3 — GEARBOX

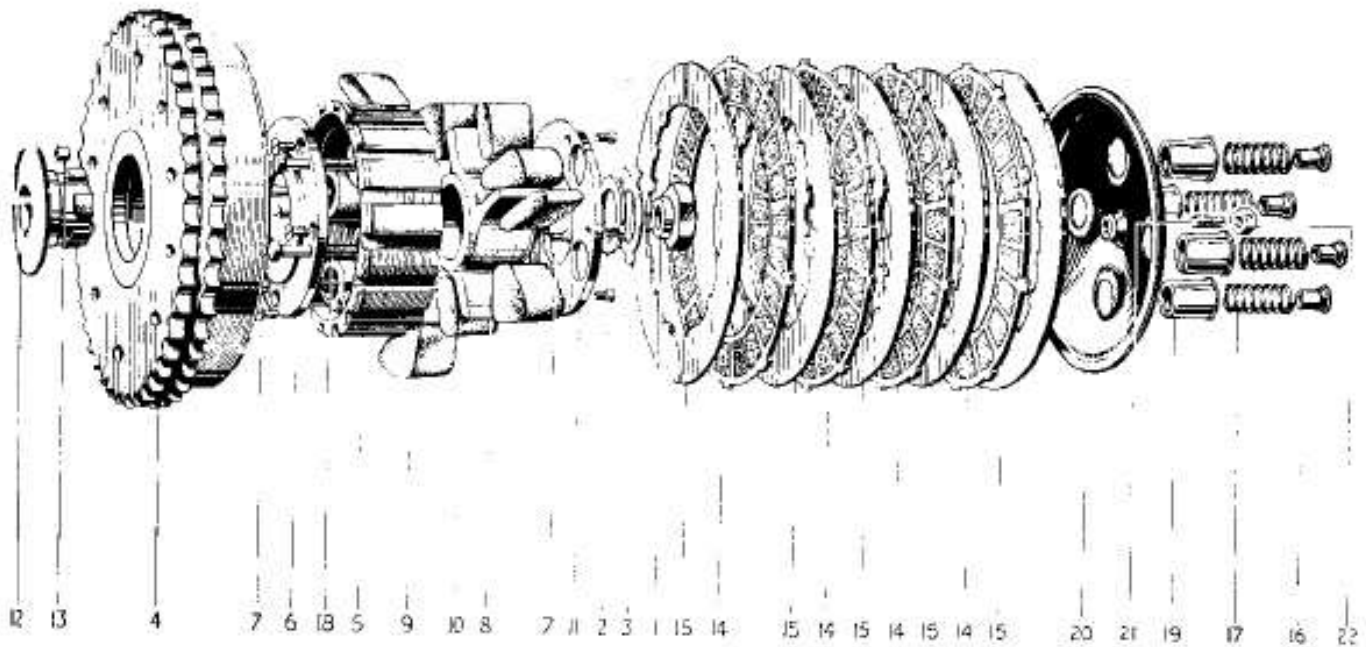

FIG. 9 CLUTCH AND SHOCK ABSORBER

### INDEX TO FIG. 9

Illust. No.	Part No.	Page No.	Ref. No.	Illust. No.	Part No.	Page No.	Ref. No.
1	T1047	29	10	12	T1306	26	33
2	T1045	29	8	13	T394	26	34
3	T1046	29	9	14	T1362	28	6
4	T1442	26	35	15	T1363	28	7
5	T1037	26	38	16	T427	29	6
6	T1039	26	37	17	T429	29	5
7	T1040	28	4	18	T423	28	5
8	T1041	26	36	19	T425	29	4
9	T1472	28	1	20	T1466	29	1
10	T1473	28	2	21	T1256	29	2
11	T1044	28	3	22	GS662	29	3

REF. No.	PART No.	DESCRIPTION	QUANTITY	
			3TA	5TA
1	T1472	Rubber, driving (large) ... ..	4	4
2	T1473	Rubber, rebound (small) ... ..	4	4
3	T1044	Plate, shock absorber, outer ... ..	1	1
4	T1040	Screw, shock absorber plates, 0.417" U.H. ... ..	8	8
5	T423	Pin, pressure spring, 1 $\frac{11}{32}$ " U.H. ... ..	4	4
6	T1362	Plate, driving (with linings) ... ..	4	4
7	T1363	Plate, driven (plain) ... ..	5	5

**GEARBOX — GROUP 3**  
**EXHAUST SYSTEM — GROUP 4**

REF. No.	PART No.	DESCRIPTION	QUANTITY	
			3TA	5TA
1	T1466	Plate, clutch pressure ... ..	1	1
2	T1256	Adjuster, pressure plate ... ..	1	1
3	GS662	Nut, adjuster lock ... ..	1	1
4	T425	Cup, pressure spring ... ..	4	4
5	T429	Spring, clutch pressure ... ..	4	4
6	T427	Nut, pressure spring ... ..	4	4
7	S66-1	Key, clutch to mainshaft ... ..	1	1
8	T1045	Washer, cupped ... ..	1	1
9	T1046	Washer, tab ... ..	1	1
10	T1047	Nut, clutch to mainshaft ... ..	1	1
11	T1456	Rod, clutch operating ... ..	1	1

**CHAINCASE COVER**

12	E3701	Cover, chaincase ... ..	1	1
13	E3850	Washer, cover joint ... ..	1	1
14	DS57	Plug, drain and level ... ..	2	2
15	WE170	Washer, drain and level plugs ... ..	2	2
16	E732	Plug, adjuster cover and filler ... ..	2	2
17	NE507	Washer, adjuster cover plug ... ..	2	2
18	E3802	Screw, chaincase cover, 2 $\frac{3}{4}$ " U.H. ... ..	3	3
19	E3668	Screw, chaincase cover, $\frac{1}{8}$ " U.H. ... ..	7	7

**For chain oiler jet see Page 15**

**EXHAUST SYSTEM—GROUP 4**

20	E3992	Pipe, exhaust L.H. ... ..	1	1
21	E3994	Pipe, exhaust R.H. ... ..	1	1
22	E1270	Clip, pipe to head ... ..	2	2
23	E410A	Washer, clip bolt ... ..	2	2
24	E409	Bolt, clip, 1 $\frac{1}{8}$ " U.H. ... ..	2	2
25	F4283	Bracket, to bottom engine stud ... ..	2	2
26	DS57	Bolt, pipe to bracket, $\frac{1}{8}$ " U.H. ... ..	2	2
27	E1612	Washer, shakeproof ... ..	2	2
28	F879	Nut, bracket bolt ... ..	1	2
29	E3935	Silencer, L.H. ... ..	1	1
30	E3936	Silencer, R.H. ... ..	1	1
31	E2271	Clip, silencer to pipe ... ..	2	2
32	TE164E	Bolt, silencer clip, 1 $\frac{1}{16}$ " U.H. ... ..	2	2
33	TE164D	"D" Washer, clip bolt ... ..	2	2
34	TE164C	"D" nut, clip bolt ... ..	2	2

## GROUP 5 — FRAME

REF. No.	PART No.	DESCRIPTION	QUANTITY
<b>FRAME—GROUP 5</b>			
1	F4157	Frame, front ... ..	3TA 1
2	KW194	Lubricator, fork pivot (grease nipple) ... ..	5TA 1
3	WE170	Washer, lubricator ... ..	1
4	F4158	Frame, rear ... ..	1
5	F2842	Stud, top rear frame, 3 $\frac{3}{8}$ " O.A. ... ..	1
6	S26-1	Washer, spring ... ..	2
7	S1-52	Nut, top stud ... ..	2
8	*F3780	Bolt, bottom rear frame, 1 $\frac{1}{16}$ " U.H. ... ..	2
9	PCW73A	Washer, spring ... ..	2

\*Footrest bolts Page 31 also secure the lower frame joint

### ENGINE PLATES AND STUDS

10	F4275	Plate, engine front L.H. ... ..	1
11	F4276	Plate, engine front R.H. ... ..	1
12	E3937	Bolt, engine plates to crankcase, (domed head) ... ..	3
13	S26-3	Washer, spring ... ..	6
14	H400	Nut, domed ... ..	3
15	F2825	Stud, engine plates to frame, 3 $\frac{1}{2}$ " O.A. ... ..	1
16	S26-1	Washer, spring ... ..	2
17	E1435	Nut, domed ... ..	2
18	E3812	Stud, engine bottom, 7 $\frac{3}{16}$ " O.A. ... ..	1
19	F4197	Distance piece, bottom stud ... ..	2
20	S26-1	Washer, spring ... ..	2
21	P0172A	Nut, bottom stud ... ..	2
22	F4229	Plate, engine rear L.H. ... ..	1
23	F4230	Plate, engine rear R.H. ... ..	1
24	F3665	Stud, engine plates to crankcase, 4 $\frac{1}{4}$ " O.A. ... ..	1
25	S26-1	Washer, spring ... ..	2
26	P0172A	Nut, engine plates stud ... ..	2
27	E3695	Stud, engine plates to frame, 4 $\frac{1}{8}$ " O.A. ... ..	2
28	S26-3	Washer, spring ... ..	4
29	S1-51	Nut, engine plates stud ... ..	4

### ENGINE TORQUE STAYS

30	E3860	Stay, engine torque L.H. ... ..	1
31	E3861	Stay, engine torque R.H. ... ..	1
32	S26-1	Washer, spring ... ..	2
33	S1-52	Nut, cylinder head bolts ... ..	2
34	E3862	Clip, stays to frame ... ..	1
35	DS58	Bolt, clip, $\frac{3}{16}$ " U.H. ... ..	1
36	S26-3	Washer, spring ... ..	1
37	S1-51	Nut, clip bolt ... ..	1

## FRAME — GROUP 5

REF. No.	PART No.	DESCRIPTION	3TA	5TA
<b>SWINGING FORK</b>				
1	F4190	FORK, SWINGING C/W BUSHES	1	1
2	F4076	Bush, fork pivot	2	2
3	F4195	Spindle, swinging fork	1	1
4	F4078	Washer, spacing R.H.	1	1
5	F4385	Shim, .003" thick	as necessary	
6	F4386	Shim, .005" thick	as necessary	
7	F3797	Rod, spindle caps	1	1
8	F4196	Cap, spindle retaining	2	2
9	F3799	Nut, retaining rod	1	1
<b>CENTRE STAND</b>				
10	F4402	Stand, centre	1	1
11	T449	Rubber, extension arm	1	1
12	F3617	Spring, stand return	1	1
13	F3619	Bolt, pivot	2	2
14	F2725	Nut, pivot bolt	2	2
<b>PROP STAND</b>				
15	F4388	Stand, prop	1	1
16	F3097	Pin, stand swivel	1	1
17	F3096	Washer, tab	1	1
18	F2610	Spring, stand return	1	1
<b>FOOTRESTS</b>				
19	F4214	Footrest, L.H.	1	1
20	F4215	Footrest, R.H.	1	1
21	NF704	Rubber, footrest	2	2
22	F4369	Bolt, footrests to frame, 2 $\frac{11}{16}$ " U.H.	2	2
23	F4370	Washer, footrest nut	2	2
24	DS47	Nut, footrest bolt	2	2
<b>PILLION FOOTRESTS</b>				
25	F4407	Support, pillion footrest L.H.	1	1
26	F4410	Support, pillion footrest, R.H.	1	1
27	E1396	Stud, support to frame, $\frac{11}{16}$ " O.A.	4	4
28	SI-51	Nut, support stud	4	4
29	S26-3	Washer, spring	4	4
30	F4327	FOOTREST, PILLION COMPLETE	2	2
31	F1694	Pedal, pillion footrest	2	2
32	F2268	Hanger, pillion footrest	2	2
33	F4309	Stud, hanger, 1 $\frac{3}{8}$ " O.A.	2	2
34	F2271	Bolt, pivot	2	2
35	F2277	Washer, Thackeray	2	2
36	SI-51	Nut, pivot bolt	2	2
37	P0172A	Nut, hanger stud	2	2
38	S26-1	Washer, spring	2	2
39	F1695	Rubber, pillion footrest	2	2

## GROUP 5 — FRAME

REF. No.	PART No.	DESCRIPTION	QUANTITY
<b>BRAKE PEDAL</b>			
			3TA      5TA
1	F4284	Spindle, brake pedal ... ..	
2	DS48	Nut, spindle to frame ... ..	
3	SCZ45	Washer, spring ... ..	
4	F4314	Pedal, brake ... ..	
5	F1149	Adjuster, pedal position, $\frac{15}{16}$ " U.H. ... ..	
6	F879	Nut, adjuster lock ... ..	
7	S26-16	Washer, spring outer ... ..	
8	S25-2	Washer, plain outer ... ..	
9	S1-52	Nut, outer ... ..	
10	F3597	Rod, brake operating ... ..	
11	S25-13	Washer, split pin ... ..	
12	—	Split pin, rod to pedal, $\frac{1}{16}$ " x $\frac{1}{2}$ " ... ..	
13	F3667	Nut, thumb adjuster brake rod ... ..	

### INDEX TO FIG. 10

Illust. No.	Part No.	Page No.	Ref. No.	Illust. No.	Part No.	Page No.	Ref. No.
1	F4157	30	1	26	E3695	30	27
2	F2842	30	5	27	F4283	29	25
3	S1-52	30	7	28	H1130	37	1
4	F4276	30	11	29	F1695	31	39
5	F2825	30	15	30	F4402	31	10
6	E1435	30	17	31	F3619	31	13
7	F4275	30	10	32	F2725	31	14
8	F4230	30	23	33	F4314	32	4
9	F4229	30	22	34	F4284	32	1
10	F3665	30	24	35	S1-52	32	9
11	F4158	30	4	36	S25-2	32	8
12	F3780	30	8	37	S26-16	32	7
13	E1396	31	27	38	F3597	32	10
14	F4407	31	25	39	Split pin	32	12
	F4410	31	26	40	S25-13	32	11
15	F4327	31	30	41	F3667	32	13
16	F4190	31	1	42	F4214	31	19
17	F4076	31	2	43	NF704	31	21
18	F4078	31	4	44	F4369	31	22
19	F4195	31	3	45	DS47	31	24
20	F3797	31	7	42	F4214	31	19
21	F4196	31	8		F4215	31	20
22	F3799	31	9	43	NF704	31	21
23	E3812	30	18	44	F4369	31	22
24	P0172A	30	21	45	DS47	31	24
25	F4197	30	19	46	T449	31	11



FRAME — GROUP 5

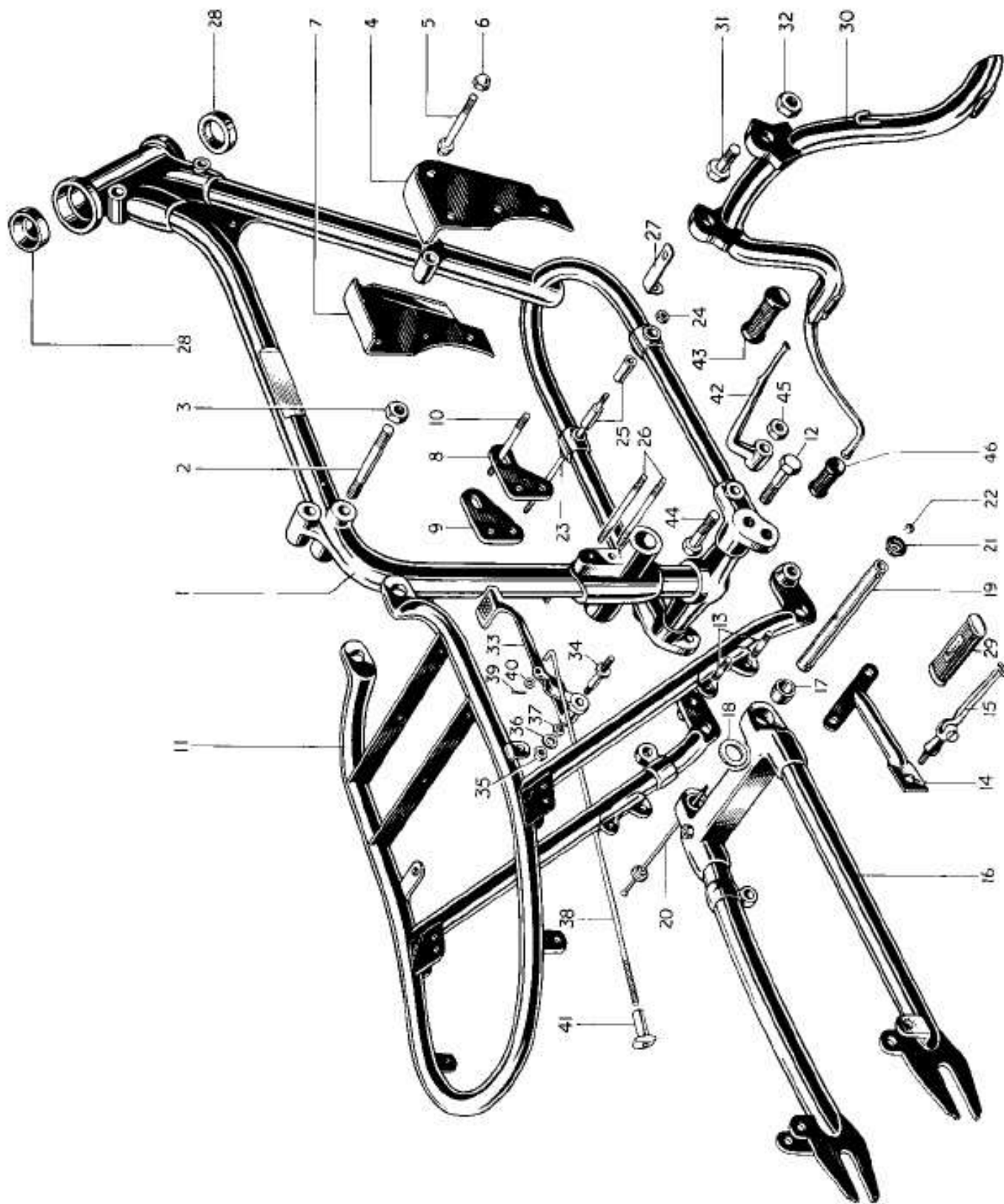

FIG. 10 FRAME AND FITTINGS

## GROUP 6 — FRONT FORK

REF. No.	PART No.	DESCRIPTION	QUANTITY
		<b>TELESCOPIC FRONT FORK—GROUP 6</b>	
			3TA      5TA
1	H1174	FORK ASSEMBLY ... ..	1      1
2	H1112	Lug, middle and stem ... ..	1      1
3	H941	Bolt, middle lug pinch, 2 $\frac{1}{4}$ " U.H. ... ..	2      2
4	S25-2	Washer, pinch bolt ... ..	2      2
5	E2412	Nut, pinch bolt ... ..	2      2
6	H1108	Lug, fork top ... ..	1      1
7	F1760	Bolt, top lug pinch, 1 $\frac{11}{16}$ " U.H. ... ..	1      1
8	H379	Nut, pinch bolt ... ..	1      1
9	H660	"U" bolt, handlebar clamp ... ..	2      2
10	S25-3	Washer, plain ... ..	4      4
11	E1310	Nut, "U" bolt ... ..	4      4
12	H1141	Nut, fork stem sleeve ... ..	1      1
13	H1123	STANCHION C/W BEARING ... ..	2      2
14	H443	Bearing, stanchion lower ... ..	2      2
15	H1058	Nut, bearing to stanchion ... ..	2      2
16	H519A	Plug, stanchion oil filler, $\frac{3}{16}$ " U.H. ... ..	2      2
17	H430	Washer, fibre ... ..	2      2

### INDEX TO FIG. II

Illust. No.	Part No.	Page No.	Ref. No.	Illust. No.	Part No.	Page No.	Ref. No.
1	H1108	34	6	28	H519A	34	16
2	F1760	34	7	29	H430	34	17
3	H379	34	8	30	H1064	36	22
4	H660	34	9	31	H443	36	14
5	E1310	34	11	32	H1058	36	15
6	H1112	34	2	33	H1127	36	21
7	H1141	34	12	34	H1062	36	12
8	H941	34	3	35	H1063	36	11
9	E2412	34	5	36	H565	36	30
10	H1145	36	26	37	H1110	37	3
11	H1146	36	27	38	H408	36	31
12	H1144	37	5	39	H409	36	32
13	H877	37	12	40	H1142	36	29
14	H878	37	13	41	H1111	36	34
15	H1194	36	15	42	F3468	36	36
16	H1117	36	1	43	S1-S1	36	38
17	H1118	36	5	44	H435	37	33
18	H1071	36	9	45	H95	36	35
19	H430	36	10	46	F3098	36	37
20	H1053	36	2	47	H1066	36	24
21	H1070	36	4	48	H1051	36	23
22	H1194	36	15	49	H1125	36	20
23	H1168	36	16	50	H1061	36	18
24	H441	36	14	51	H1060	36	19
25	H1126	36	13	52	H1140	37	2
26	H420	36	28	53	H992	37	8
27	H1123	34	13	54	H993	37	9

FRONT FORK — GROUP 6

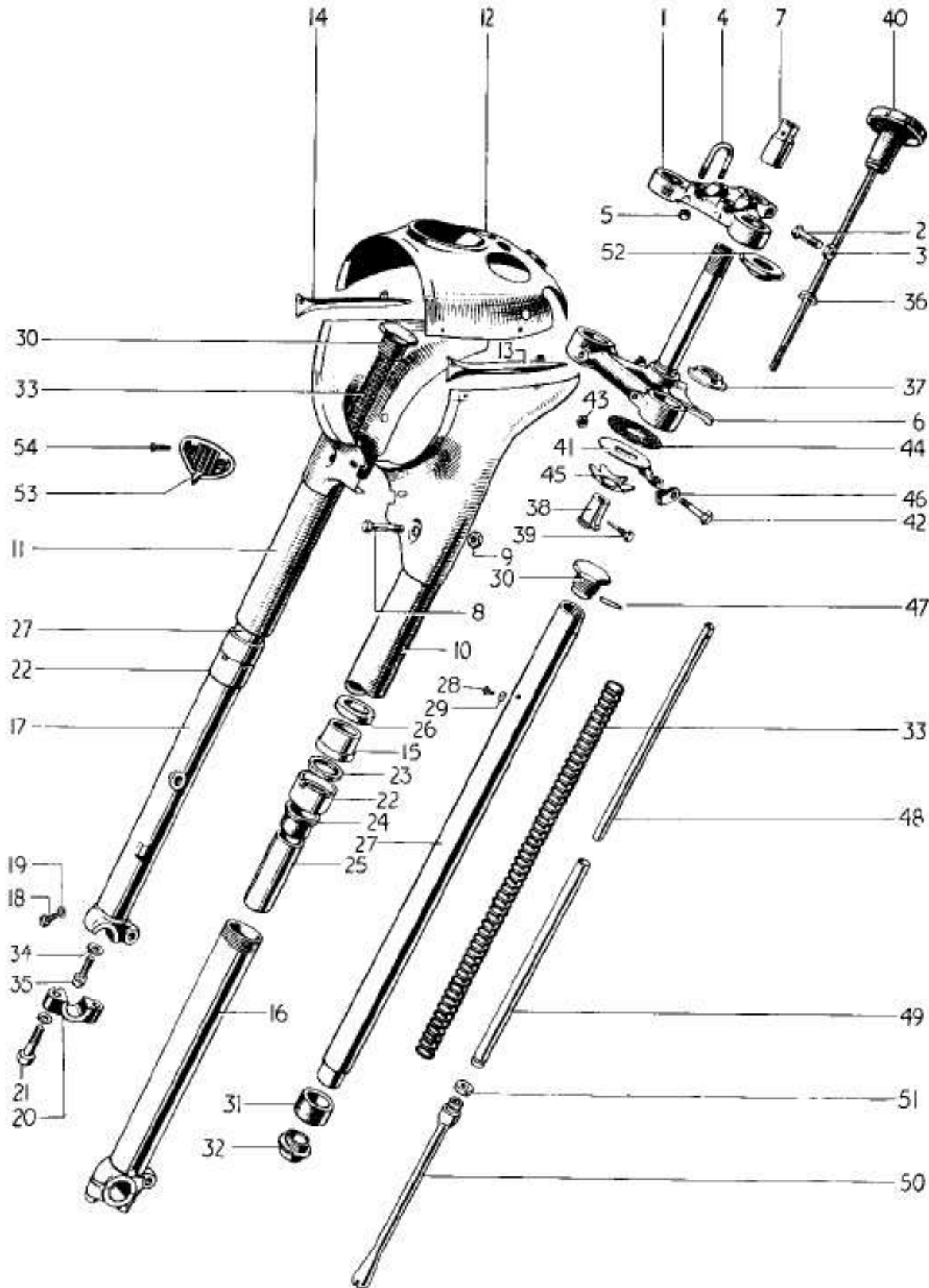

FIG. 11 TELESCOPIC FRONT FORK

## GROUP 6 — FRONT FORK

REF. No.	PART No.	DESCRIPTION	3TA	STA
1	H1117	BOTTOM MEMBER, L.H. COMPLETE	1	1
2	H1053	Cap, wheel spindle	1	1
3	S26-3	Washer, spring	2	2
4	H1070	Bolt, spindle cap, $1\frac{7}{16}$ " U.H.	2	2
5	H1118	BOTTOM MEMBER, R.H. COMPLETE	1	1
6	H1053	Cap, wheel spindle	1	1
7	S26-3	Washer, spring	2	2
8	H1070	Bolt, spindle cap, $1\frac{7}{16}$ " U.H.	2	2
9	H1071	Plug, drain	2	2
10	H430	Washer, fibre	2	2
11	H1063	Bolt, restrictor to bottom lug, $\frac{7}{8}$ " U.H.	2	2
12	H1062	Washer, aluminium	2	2
13	H1126	Sleeve, bottom member	2	2
14	H441	Bearing, bottom member	2	2
15	H1194	NUT, DUST EXCLUDER SLEEVE	2	2
16	H1168	Oil Seal	2	2
17	H1124	RESTRICTOR ROD ASSEMBLY	2	2
18	H1061	Rod, restrictor	2	2
19	H1060	Washer, spring support	2	2
20	H1125	Tube, lower guide	2	2
21	H1127	Spring, main (identification YELLOW)	2	2
22	H1064	CAP NUT ASSEMBLY	2	2
23	H1051	Tube, upper guide	2	2
24	H1066	Pin, tube to nut	2	2
25	H1065	Nut, stanchion cap	2	2
26	H1145	Cover, nacelle L.H.	1	1
27	H1146	Cover, nacelle R.H.	1	1
28	H420	Washer, nacelle cover (rubber)	2	2
29	H1142	Rod and knob, steering damper	1	1
30	H565	Washer, abutment	1	1
31	H408	Sleeve, damper adjusting	1	1
32	H409	Pin, sleeve to middle lug	1	1
33	H435	Disc, friction	1	1
34	H1111	Plate, damper anchor	1	1
35	H95	Spring, anchor plate	1	1
36	F3468	Bolt, damper anchor, $2\frac{1}{16}$ " U.H.	1	1
37	F3098	Clip, speedometer cable	1	1
38	S1-51	Nut, anchor bolt	1	1

## FRONT FORK — GROUP 6

REF. No.	PART No.	DESCRIPTION	3TA	5TA
<b>STEERING RACES</b>				
1	H1130	Cup, frame lug, top and bottom ... ..	2	2
2	H1140	Cone and dust cover, top lug ... ..	1	1
3	H1110	Cone, middle lug ... ..	1	1
4	S70-4	Ball, top and bottom races, $\frac{3}{16}$ " dia. ... ..	48	48
<b>NACELLE TOP AND MOTIFS</b>				
5	H1144	Top unit, nacelle ... ..	1	1
6	H961	Grommet, control cables ... ..	3	3
7	H669	Grommet, handlebar ... ..	2	2
8	H992	Grille, horn ... ..	1	1
9	H993	Screw, grille fixing, 0.540" U.H. ... ..	2	2
10	GS299	Washer, shakeproof ... ..	2	2
11	F3799	Nut, grille screw ... ..	2	2
12	H877	Motif (flash), L.H. ... ..	1	1
13	H878	Motif (flash), R.H. ... ..	1	1
14	H688	Screw, motif front, $\frac{5}{16}$ " U.H. ... ..	2	2
15	H689	Screw, top and bottom units, $\frac{1}{4}$ " U.H. ... ..	2	2
16	E2880	Washer, shakeproof ... ..	4	4
17	H691	Nut, front and rear screws ... ..	4	4
18	H687	Screw, motif to top lug, $\frac{3}{4}$ " U.H. ... ..	2	2

### SPECIAL WORKSHOP TOOLS

A COMPLETE LIST OF WORKSHOP TOOLS CAN BE MADE AVAILABLE BY EITHER CONTACTING YOUR DEALER OR APPLYING DIRECT TO THE TRIUMPH SERVICE DEPARTMENT. IN MOST CASES THESE TOOLS ARE VERY COSTLY AS THEY ARE MADE ENTIRELY FOR WORKSHOP USE, AND THEREFORE, IT IS NOT RECOMMENDED THAT THE PRIVATE OWNER PURCHASES THE TOOLS IN ORDER TO AID SERVICING THE MACHINE ONCE OR TWICE ONLY. IN THESE CIRCUMSTANCES IT IS FAR MORE ECONOMICAL TO GET IN TOUCH WITH A RECOGNISED DEALER.

## GROUP 7—FRONT WHEEL

REF. No.	PART No.	DESCRIPTION	QUANTITY	
			3TA	5TA
<b>FRONT WHEEL—GROUP 7</b>				
1	W1311	WHEEL, FRONT COMPLETE ... ..	1	1
2	W1273	RIM, SPOKES AND HUB ASSEMBLY ...	1	1
3	W1274	Rim, WM2-17 ... ..	1	1
4	W1275	Spoke, straight, 5 $\frac{1}{16}$ " c/w nipple ...	40	40
5	S79-2	Nipple ... ..	40	40
6	W1231	Brake drum and hub ... ..	1	1
7	W1334	Plate, hub cover L.H. ... ..	1	1
8	W653	Bearing, L.H. and R.H. ... ..	2	2
9	W1237	Cover, L.H. bearing ... ..	1	1
10	T280	Circlip, L.H. bearing cover ... ..	1	1
11	W1238	Ring, R.H., bearing backing ... ..	1	1
12	W582	Ring, nut, R.H., bearing retaining ...	1	1
13	W1239	Spindle, front wheel ... ..	1	1

### INDEX TO FIG. 12

Illust. No.	Part No.	Page No.	Ref. No.	Illust. No.	Part No.	Page No.	Ref. No.
1	W1334	38	7	13	W1301	40	1
2	T280	38	10	14	W592	40	12
3	W1237	38	9	15	W1298	40	11
4	W653	38	8	16	S25-6	40	14
5	W1239	38	13	17	S1-52	40	13
6	S79-2	38	5	18	W135	40	9
7	W1275	38	4	19	W1302	40	2
8	W1231	38	6	20	NW243	40	7
9	W1238	38	11	21	W129	40	8
10	W582	38	12	22	W1246	40	10
11	W93	40	6	23	S25-2	40	3
12	W1243	40	5	24	E1435	40	4

# FRONT WHEEL — GROUP 7

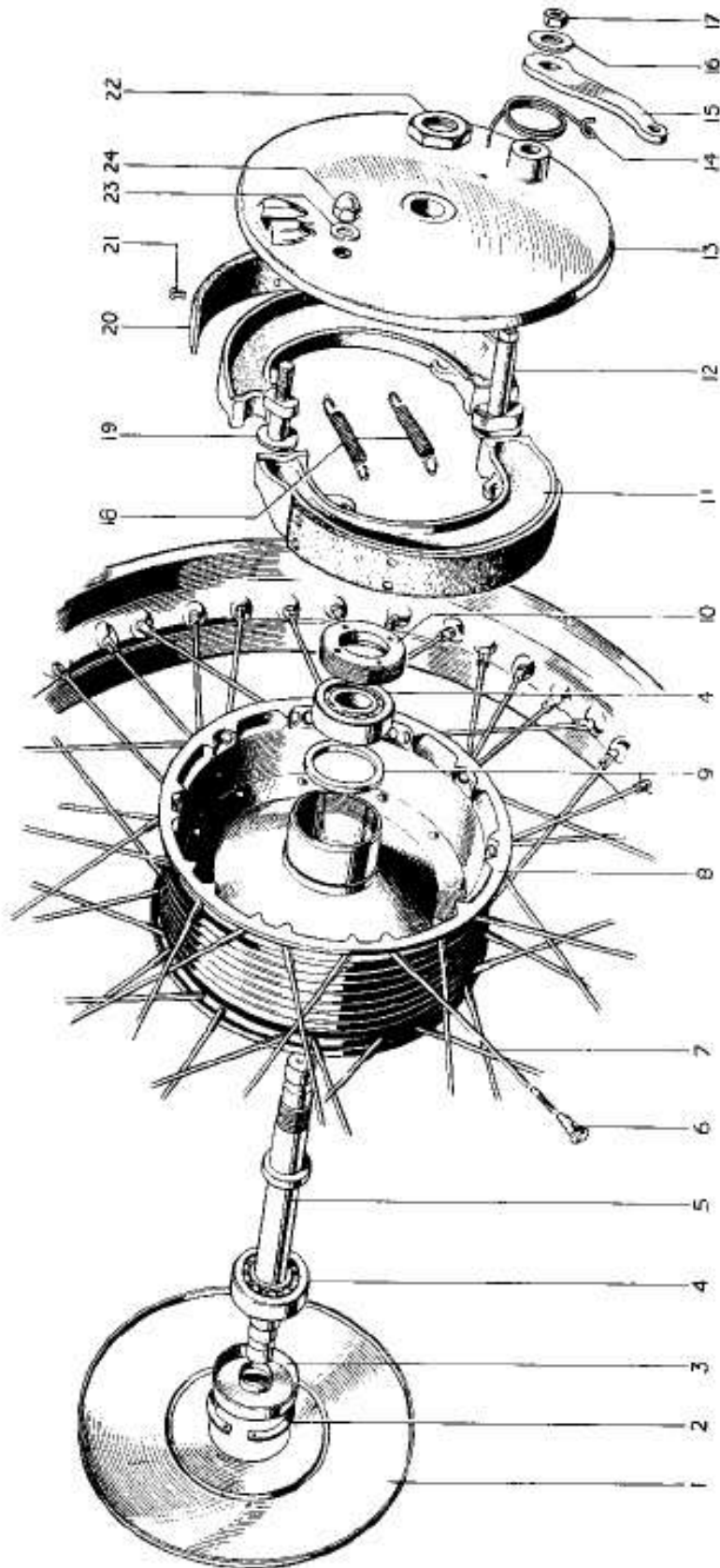

FIG. 12 FRONT WHEEL

## GROUP 7 — FRONT WHEEL

REF. No.	PART No.	DESCRIPTION	QUANTITY	
FRONT BRAKE			3TA	5TA
1	WI301	Plate, front brake anchor ... ..	1	1
2	WI302	Pin, shoe fulcrum ... ..	1	1
3	S25-2	Washer, nut ... ..	1	1
4	E1435	Nut, fulcrum pin domed ... ..	1	1
5	WI243	Cam, brake operating ... ..	1	1
6	W93	SHOE, BRAKE C/W LINING ... ..	2	2
7	NW243	Lining, brake shoe ... ..	2	2
8	WI29	Rivet, brake lining ... ..	16	16
9	WI35	Spring, shoe return ... ..	2	2
10	WI246	Nut, anchor plate to spindle ... ..	1	1
11	WI298	Lever, brake cam ... ..	1	1
12	W592	Spring, lever return ... ..	1	1
13	SI-52	Nut, lever to cam ... ..	1	1
14	S25-6	Washer, lever nut ... ..	1	1
15	WF32	Pin, cable to lever ... ..	1	1
16	—	Split pin, $\frac{1}{16}$ " x $\frac{1}{2}$ " ... ..	1	1

### INDEX TO FIG. 13

Illust. No.	Part No.	Page No.	Ref. No.	Illust. No.	Part No.	Page No.	Ref. No.
1	F1747	42	39	20	SI-52	42	26
2	WI282	42	28	21	WI090	42	25
3	WI316	42	24	22	WI35	42	23
4	WI112	42	18	23	WI083	42	19
5	W93	42	20	24	WI079	42	16
6	NW243	42	21	25	WI021	42	15
7	WI29	42	22	26	WI022	42	14
8	WI024	42	27	27	WI266	42	7
9	WI276	42	8	28	WI271	42	5
10	W63	42	10	29	S79-2	42	6
11	W62	42	9	30	WI270	42	4
12	WI278	42	17	31	WI281	42	12
13	WI271	42	5	32	WI277	42	29
14	WI270	42	4	33	SI-51	42	11
15	W653	42	13	34	WI272	42	3
16	D557	42	30	35	D373	42	33
17	WI134	42	36	36	WI279	42	32
18	WI015	42	37	37	WI280	42	34
19	WI058	42	38				



# REAR WHEEL — GROUP 8

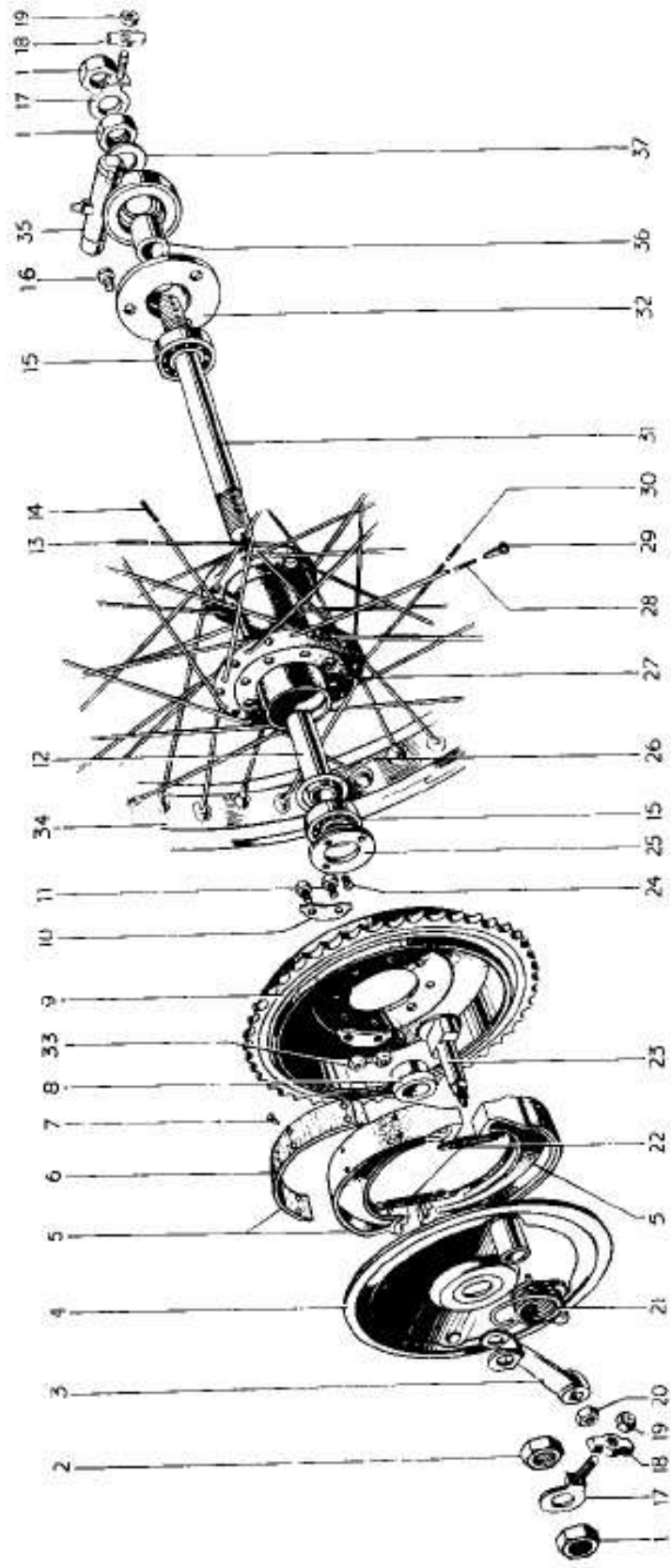

FIG. 13 REAR WHEEL

## GROUP 8 — REAR WHEEL

REF. No.	PART No.	DESCRIPTION	QUANTITY	3TA	5TA
<b>REAR WHEEL—GROUP 8</b>					
1	WI1313	WHEEL, REAR COMPLETE	1	1	1
2	WI265	RIM, SPOKES AND HUB ASSEMBLY	1	1	1
3	WI272	Rim, WM2-17	1	1	1
4	WI270	Spoke, inner, 110° x 7 $\frac{1}{8}$ " c/w nipple	20	20	20
5	WI271	Spoke, outer, 90° x 7 $\frac{1}{8}$ " c/w nipple	20	20	20
6	S79-2	Nipple	40	40	40
7	WI266	Hub	1	1	1
8	WI276	Brake drum and sprocket, 43T	1	1	1
9	W62	Bolt, drum to hub, $\frac{11}{16}$ " U.H.	8	8	8
10	W63	Lockplate, bolt and nut	8	8	8
11	SI-51	Nut, drum bolt	8	8	8
12	WI281	Spindle, wheel	1	1	1
13	W653	Bearing, L.H. and R.H.	2	2	2
14	WI022	Ring, L.H., bearing backing	1	1	1
15	WI021	RING, L.H., BEARING RETAINING	1	1	1
16	WI079	Screw, retainer locking	1	1	1
17	WI278	Tube, bearing distance	1	1	1
<b>REAR BRAKE</b>					
18	WI112	Plate, rear brake anchor	1	1	1
19	WI083	Cam, brake operating	1	1	1
20	W93	SHOE, BRAKE C/W LINING	2	2	2
21	NW243	Lining, brake shoe	2	2	2
22	WI29	Rivet, brake lining	2	2	2
23	WI35	Spring, shoe return	2	2	2
24	WI316	Lever, brake operating	1	1	1
25	WI090	Spring, lever return	1	1	1
26	SI-52	Nut, lever to cam	1	1	1
27	WI024	Distance, piece, anchor plate	1	1	1
28	WI282	Nut, anchor plate to spindle	1	1	1
<b>SPEEDOMETER DRIVE</b>					
29	WI277	Adaptor, speedometer drive	1	1	1
30	D557	Bolt, adaptor to hub, $\frac{7}{16}$ " U.H.	3	3	3
31	E1612	Washer, shakeproof	3	3	3
32	WI279	Distance piece, gearbox	1	1	1
33	D373	Gearbox, speedometer drive	1	1	1
34	WI280	Washer, plain	1	1	1
35	F1747	Nut, gearbox to spindle	1	1	1
<b>CHAIN ADJUSTERS</b>					
36	WI134	Adjuster, rear chain	2	2	2
37	WI015	Plate, adjuster end	2	2	2
38	WI058	Nut, adjuster end plate	2	2	2
39	F1747	Nut, spindle outer	2	2	2

**FRONT MUDGUARD—GROUP 9**  
**REAR MUDGUARD—GROUP 10**

REF. No.	PART No.	DESCRIPTION	QUANTITY
<b>FRONT MUDGUARD—GROUP 9</b>			
			3TA      5TA
1	H1097	Mudguard, front ... ..	1      1
2	F4299	Washer, mudguard bolt ... ..	2      2
3	F929	Bolt, mudguard to fork leg, $\frac{1}{2}$ " U.H. ... ..	2      2
4	H1171	Clip, front brake cable ... ..	1      1
5	H916	Screw, clip, $\frac{3}{32}$ " U.H. ... ..	1      1
6	GS299	Washer, clip ... ..	1      1
7	H745	Nut, clip ... ..	1      1
<b>FRONT STAND</b>			
8	H1100	Stand, front ... ..	1      1
9	W62	Bolt, stand pivot, $\frac{11}{16}$ " U.H. ... ..	2      2
10	S25-2	Washer, pivot bolt ... ..	2      2
11	NS362	Nut, mudguard to stand ... ..	1      1
<b>FRONT NUMBER PLATE</b>			
12	F2698	Plate, front number ... ..	1      1
13	H251	Beading, rubber ... ..	1      1
14	F4332	Packing piece, front ... ..	1      1
15	F879	Nut, plate to mudguard ... ..	2      2
16	S26-2	Washer, spring ... ..	2      2
<b>LICENCE HOLDER</b>			
17	D261	Licence holder ... ..	1      1
18	DS57	Bolt, to mudguard, $\frac{7}{16}$ " U.H. ... ..	1      1
19	E1612	Washer, shakeproof ... ..	1      1
20	F879	Nut ... ..	1      1
<b>REAR MUDGUARD AND PANELS—GROUP 10</b>			
<b>REAR MUDGUARD</b>			
21	F4297	Mudguard, rear ... ..	1      1
22	DS57	Bolt, to bottom frame lug, $\frac{7}{16}$ " U.H. ... ..	1      1
23	S26-2	Washer, spring ... ..	1      1
24	GS218	Bolt, to top rail bracket, $\frac{9}{16}$ " U.H. ... ..	1      1
25	S25-13	Washer, top bolt ... ..	1      1
26	F879	Nut, top bolt ... ..	1      1
<b>REAR PANELS</b>			
27	F4144	Panel, L.H., rear ... ..	1      1
28	F4145	Panel, R.H., rear ... ..	1      1
29	F4312	Motif, "Twenty-one" ... ..	2      —
30	F4523	Motif, "Speed Twin" ... ..	—      2
31	F4317	Spire nut, motif ... ..	6      6
32	F4325	Screw, self-tapping (4 top, 2 front) ... ..	6      6
33	F4326	Spire nut, front screws ... ..	2      2
34	F4249	Beading, rubber rear ... ..	1      1
35	F1369	Bolt, rear joint and number plate top, $\frac{5}{8}$ " U.H. ... ..	3      3
36	S25-13	Washer, plain ... ..	3      3
37	F879	Nut ... ..	3      3

**GROUP 10 — REAR MUDGUARD**  
**GROUP 11 — REAR CHAINGUARD**

REF. No.      PART No.      DESCRIPTION      QUANTITY

**REAR NUMBER PLATE**

			3TA	STA
1	F4245	Plate, rear number ... ..	1	1
2	F1369	Bolt, bottom, $\frac{3}{8}$ " U.H. ... ..	2	2
3	S26-2	Washer, spring ... ..	2	2
4	F879	Nut ... ..	2	2

Top bolt also secures panel joint

**REAR CHAINGUARDS—GROUP 11**

**UPPER REAR CHAINGUARD**

5	F4198	Chainguard, upper ... ..	1	1
6	F4134	Bracket, front pivot ... ..	1	1
7	DS57	Bolt, bracket to fork, $\frac{7}{16}$ " U.H. ... ..	1	1
8	S26-2	Washer, spring ... ..	1	1
9	F4135	Bolt, pivot ... ..	1	1
10	F2277	Washer, Thackeray (spring) ... ..	1	1
11	S25-13	Washer, plain ... ..	1	1
12	F879	Nut, pivot bolt ... ..	1	1
13	F4136	Bolt, rear ... ..	1	1
14	S25-3	Washer, plain ... ..	1	1
15	S1-51	Nut, rear bolt ... ..	1	1

**LOWER REAR CHAINGUARD**

16	F4199	Chainguard, lower ... ..	1	1
17	W840	Bolt, chainguard to fork, $\frac{11}{16}$ " U.H. ... ..	1	1
18	E2288	Washer, shakeproof ... ..	1	1
19	DS47	Nut, chainguard to brake plate ... ..	1	1
20	PCW73A	Washer, spring ... ..	1	1

**INDEX TO FIG. 14**

Illust. No.	Part No.	Page No.	Ref. No.	Illust. No.	Part No.	Page No.	Ref. No.
1	F4145	43	28	14	F4136	44	13
2	F4144	43	27	15	S1-51	44	15
3	F4325	43	32	16	F4134	44	6
4	F4249	43	34	17	F2277	44	10
5	F4245	44	1	18	F4135	44	9
6	F1369	44	2	19	F879	44	12
7	F1369	43	35	20	DS-57	44	7
8	F879	43	37	21	F4199	44	16
9	F4312	43	29	22	W840	44	17
10	F4317	43	31	23	F3098	48	10
11	F4297	43	21	24	F879	44	4
12	DS-57	43	22	25	F4523	43	30
13	F4198	44	5				

REAR CHAINGUARD — GROUP 11

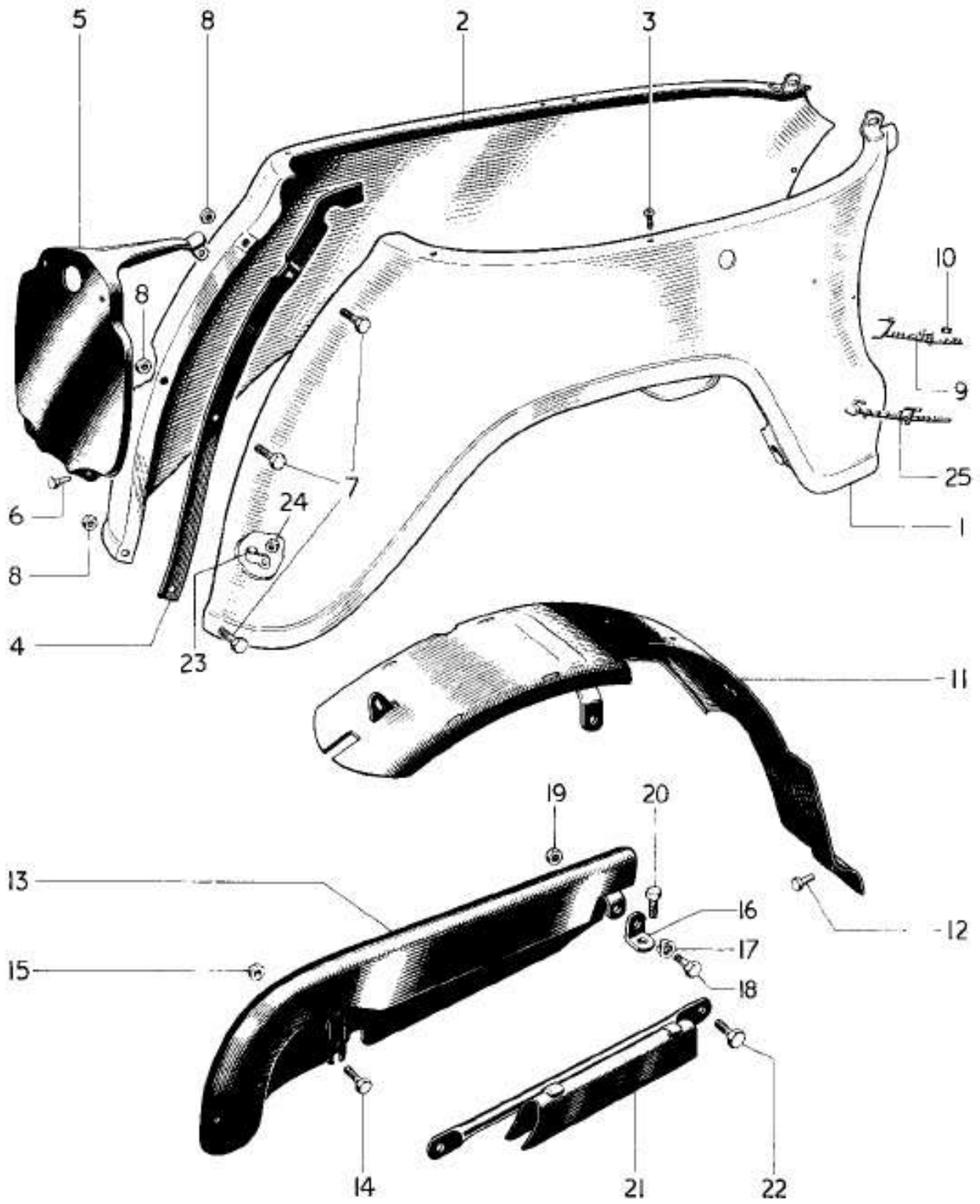

FIG. 14 REAR MUDGUARD, CHAINGUARD AND PANELS

## GROUP 12—PETROL TANK

REF. No.	PART No.	DESCRIPTION	QUANTITY	
<b>PETROL TANK—GROUP 12</b>			3TA	5TA
1	F4232	Tank, petrol ... ..	1	1
2	F3220	CAP, PETROL FILLER	1	1
3	F4048	Washer, cap joint	1	1
4	F4235	Styling strip, L.H., front	1	1
5	F4323	Styling strip, L.H., rear	1	1
6	F4237	Styling strip, R.H., front	1	1
7	F4324	Styling strip, R.H., rear	1	1
8	F4127	Styling unit, L.H.	1	1
9	F4128	Styling unit, R.H.	1	1
10	F4129	Screw, unit securing, .435" U.H.	4	4
11	F4398	Styling strip, centre	1	1
12	F4019	Washer, shakeproof	1	1
13	H919	Nut, centre strip	1	1
14	F2551	Knee grip, L.H.	1	1
15	F2552	Knee grip, R.H.	1	1
16	F1953	Screw, knee grip securing, $\frac{5}{8}$ " U.H.	4	4
17	F4384	Plug, parcel grid screw holes	4	4
18	F4382	Bolt, tank to frame front, $3\frac{1}{2}$ " U.H.	1	1
19	E1435	Nut, front bolt domed	1	1
20	E327	Bolt, tank to frame rear, $3\frac{3}{8}$ " U.H.	1	1
21	W76	Nut, rear bolt	1	1
22	E2288	Washer, shakeproof front and rear	2	2
<b>PETROL TAP AND PIPE</b>				
23	F1717	Tap, petrol feed	1	1
24	F1511	Washer, tap to tank	1	1
25	F4308	Pipe, petrol feed (complete)	1	1

### INDEX TO FIG. 15

Illust. No.	Part No.	Page No.	Ref. No.	Illust. No.	Part No.	Page No.	Ref. No.
1	F4232	46	1	13	F4129	46	10
2	F3220	46	2	14	F4127	46	8
4	F2936	48	2	15	F4235	46	4
5	F4398	46	11	16	F4476	48	3
8	F4019	46	12	17	F4477	48	4
9	H919	46	13	18	S1-51	48	8
10	F2551	46	14	19	F1213	48	6
11	F1717	46	23	20	F1713	48	12
12	F4323	46	5	21	F4533	48	11

PETROL TANK — GROUP 12

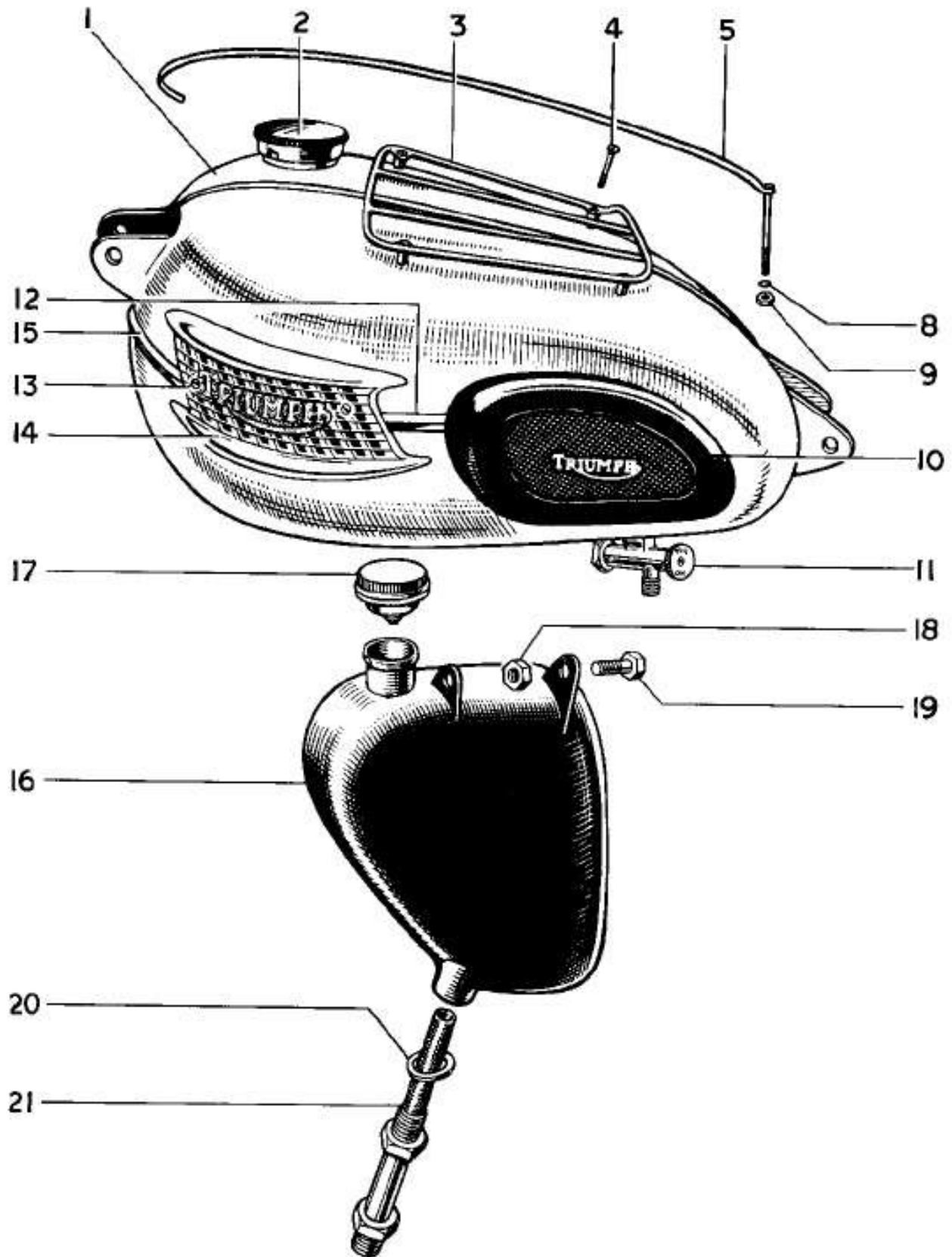

FIG. 15 PETROL AND OIL TANKS

**GROUP 12 — PETROL TANK****GROUP 13 — OIL TANK****GROUP 14 — TOOL KIT**

REF. No.	PART No.	DESCRIPTION	QUANTITY	
		<b>PARCEL GRID</b>		
1	F3917	Grid, petrol tank parcel ... ..	1	3TA
2	F2936	Screw, grid to tank, 1 $\frac{1}{8}$ " U.H. ... ..	4	5TA
		<b>OIL TANK—GROUP 13</b>		
3	F4476	Tank, oil ... ..	1	1
4	F4477	CAP, OIL FILLER ... ..	1	1
5	F4478	Washer, cap joint ... ..	1	1
6	F1213	Bolt, tank to top bracket, $\frac{3}{16}$ " U.H. ... ..	2	2
7	S26-3	Washer, spring ... ..	2	2
8	S1-51	Nut, tank bolt ... ..	2	2
9	T1579	Pipe, tank vent (flexible) ... ..	1	1
10	F3098	Clip, vent pipe to number plate bolt ... ..	1	1
		<b>OIL FILTER AND PIPES</b>		
11	F4533	Filter, oil tank ... ..	1	1
12	F1713	Washer, filter to tank ... ..	1	1
13	F3655	Pipe, oil feed top half ... ..	1	1
14	F3182	Nut, pipe to filter union ... ..	1	1
15	E3853	Junction block, oil pipes to engine ... ..	1	1
16	E3763	Washer, junction block to crankcase ... ..	1	1
17	E1310	Nut, junction block stud ... ..	1	1
18	S25-3	Washer, plain ... ..	1	1
19	MF119/20	Connection, feed and return pipes (rubber) ... ..	2	2
20	E3383	Connection, rocker oil feed pipe (rubber) ... ..	1	1
		<b>TOOLKIT—GROUP 14</b>		
21	F4319	Tooltray, rubber moulded ... ..	1	1
22	D360	Spanner, open ended, $\frac{1}{8}$ " x $\frac{9}{32}$ " Whit. ... ..	1	1
23	NA55	Spanner, open ended, $\frac{1}{4}$ " x $\frac{5}{16}$ " Whit. ... ..	1	1
24	DA16	Spanner, open ended, $\frac{3}{8}$ " x $\frac{7}{16}$ " Whit. ... ..	1	1
25	D370	Spanner, closed, $\frac{3}{16}$ " x $\frac{1}{4}$ " Whit. ... ..	1	1
26	PA57	Spanner, closed, $\frac{1}{2}$ " x $\frac{9}{16}$ " Whit. ... ..	1	1
27	D311	Spanner, closed, $\frac{5}{8}$ " x $\frac{11}{16}$ " Whit. ... ..	1	1
28	D362	Spanner, "C" and tappet key ... ..	1	1
29	DA50/1	Extractor, clutch centre ... ..	1	1
30	D87	Spanner, box sparking plug ... ..	1	1
31	D363	Tommybar, tyre lever and screwdriver ... ..	1	1
32	D364	Clutch key and tyre lever ... ..	1	1
33	D336	Screwdriver, Phillips No. 3 ... ..	1	1
34	400935	Screwdriver, ignition and feeler gauge ... ..	1	1
35	D296	Inflator, tyre (12" long) ... ..	1	1



TOOLKIT — GROUP 14

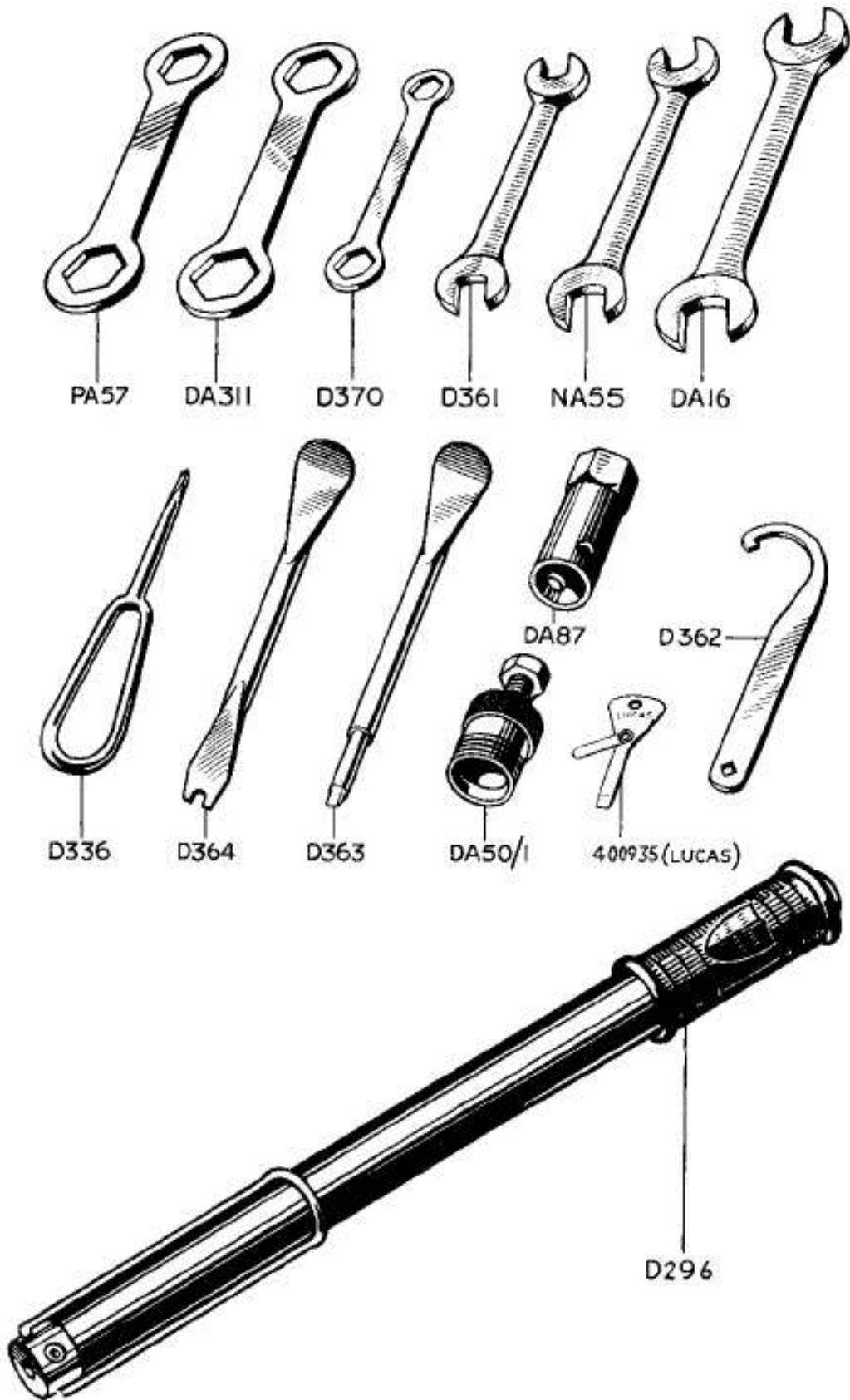

FIG. 16 TOOLKIT

## GROUP 15 — TWINSEAT

REF. No.	PART No.	DESCRIPTION	3TA	5TA
<b>TWINSEAT—GROUP 15</b>				
1	F4360	TWINSEAT C/W SAFETY STRAP (EXPORT)	A	A
2	F4239	TWINSEAT ... ..	1	1
3	F4361	Strap assembly (EXPORT) ... ..	A	A
4	F4365	Screw, strap to seat (4 off) ... ..	A	A
5	F4244	Cover, twinseat c/w clips ... ..	1	1
6	F4475	Clip, cover to pan ... ..	as required	
7	F4222	Hinge, twinseat ... ..	2	2
8	DS57	Bolt, hinge to seat, $\frac{7}{16}$ " U.H. ... ..	4	4
9	S26-2	Washer, spring ... ..	4	4
10	D374	Wire, check ... ..	1	1
11	F4325	Screw, check wire to seat ... ..	1	1
12	F4226	Plunger, seat catch ... ..	1	1
13	F4228	Spring, seat catch ... ..	1	1
14	E1719A	Washer, plain ... ..	1	1
15	—	Split pin, $\frac{3}{32}$ " x $\frac{3}{8}$ " ... ..	1	1
16	F4227	Knob, seat catch ... ..	1	1

### INDEX TO FIG. 17

Illust. No.	Part No.	Page No.	Ref. No.	Illust. No.	Part No.	Page No.	Ref. No.
1	F4239	50	2	8	DS57	50	8
2	F4361	50	3	9	F4227	50	16
3	F4365	50	4	10	F4226	50	12
4	F4244	50	5	11	F4228	50	13
5	D374	50	10	12	E1719A	50	14
6	F4325	50	11	13	$\frac{3}{32}$ " x $\frac{3}{8}$ " Split	50	15
7	F4222	50	7		pin		

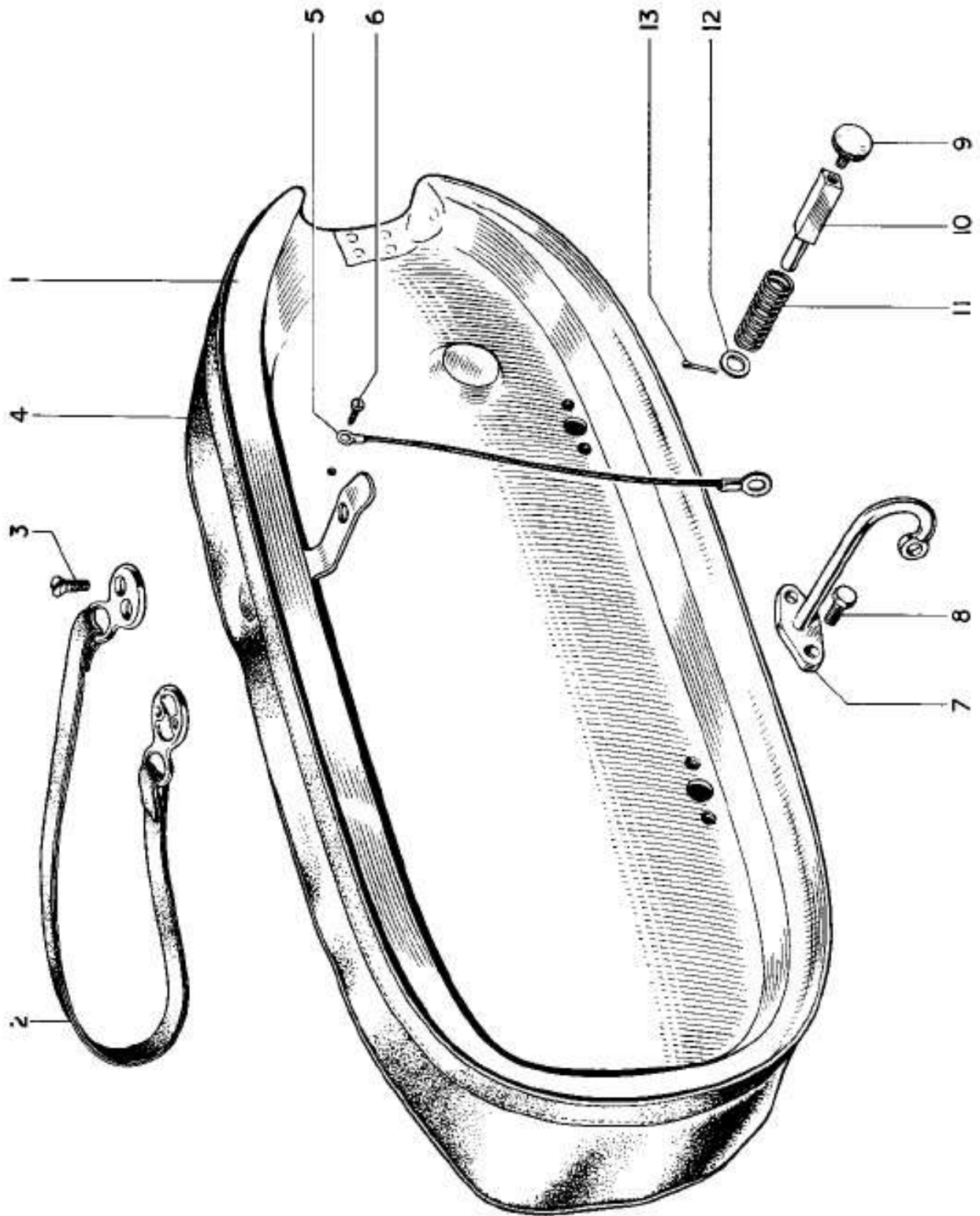

FIG. 17 TWINSEAT AND FITTINGS

## GROUP 16 — HANDLEBAR

REF. No.	PART No.	DESCRIPTION	QUANTITY	
<b>HANDLEBAR—GROUP 16</b>			3TA	5TA
1	H1176	HANDLEBAR C/W CONTROLS ... ..	1	1
2	H1131	Handlebar ... ..	1	1
3	H230	Grip, handlebar L.H. rubber ... ..	1	1
4	H1247	Handlebar (American pattern) ... ..	A	A
<b>THROTTLE CONTROL</b>				
5	H697	TWISTGRIP ASSEMBLY ... ..	1	1
6	H698	Head assembly, twistgrip ... ..	1	1
7	H665	Screw, friction adjuster ... ..	1	1
8	H685	Spring, adjuster screw ... ..	1	1
9	H686	Spring, friction ... ..	1	1
10	H234	Thimble, throttle cable ... ..	1	1
11	H237	Grubscrew, twistgrip ... ..	1	1
12	H700	Sleeve, twistgrip ... ..	1	1
13	H233	Plate, sleeve retaining ... ..	2	2
14	H232	Circlip, sleeve retaining ... ..	1	1
15	H230	Grip, twistgrip rubber ... ..	1	1
<b>FRONT BRAKE CONTROL</b>				
16	18/886	LEVER ASSEMBLY, FRONT BRAKE ... ..	1	1
17	18/535	Lever only, R.H. ... ..	1	1
18	18/890	Bracket, lever fulcrum ... ..	1	1
19	18/838	Screw, adjuster ... ..	1	1
20	18/839	Nut, thumb ... ..	1	1
21	12/044	Clamp, lever bracket ... ..	1	1
22	11/014	Screw, bracket to clamp ... ..	2	2
23	18/087	Screw, lever fulcrum ... ..	1	1
24	18/053	Nut, fulcrum screw ... ..	1	1
25	18/880	Nipple, slotted barrel ... ..	1	1

### INDEX TO FIG. 18

Illust. No.	Part No.	Page No.	Ref. No.	Illust. No.	Part No.	Page No.	Ref. No.
1	H1131	52	2	11	61/004	54	7
2	H230	52	3	12	18/087	54	8
3	H698	52	5	13	18/053	54	9
4	H234	52	10	14	18/886	52	16
5	H700	52	12	15	H689	63	22
6	H233	52	13	16	31563A	63	20
7	H232	52	14		863082	63	21
8	18/528	54	2	17	18/839	54	5
9	18/892	54	3	18	18/838	54	4
10	H668	54	6				

# HANDLEBAR — GROUP 16

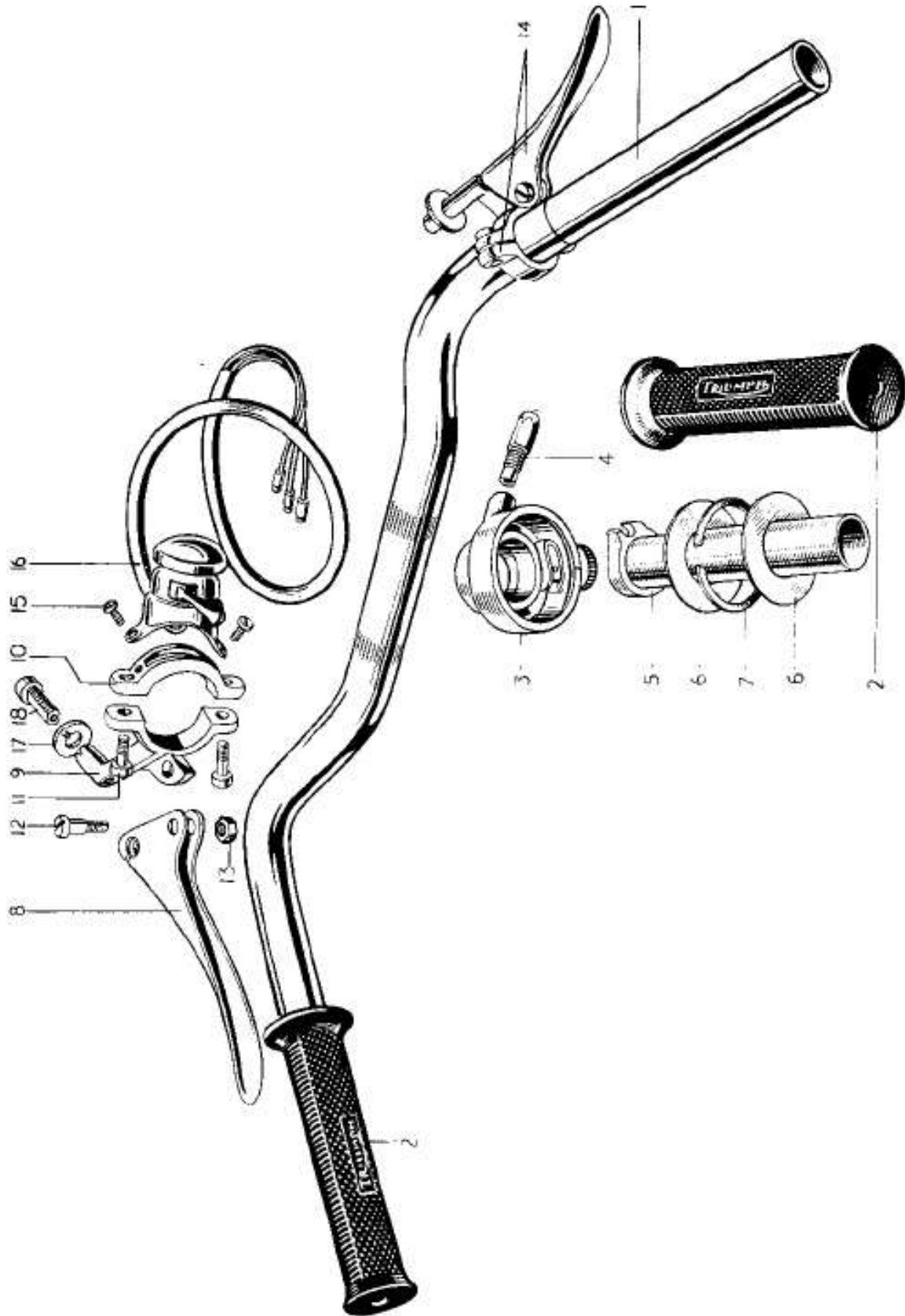

FIG. 18 HANDLEBAR AND CONTROLS

**GROUP 16 — HANDLEBAR**  
**GROUP 17 — CONTROL CABLES**

REF. No.	PART No.	DESCRIPTION	QUANTITY
<b>CLUTCH CONTROL</b>			
			3TA      5TA
1	18/894	LEVER ASSEMBLY, CLUTCH ... ..	
2	18/528	Lever only, L.H. ... ..	
3	18/892	Bracket, lever fulcrum ... ..	
4	18/838	Screw, adjuster ... ..	
5	18/839	Nut, thumb ... ..	
6	H668	Clamp, lever bracket ... ..	
7	61/004	Screw, bracket to clamp ... ..	2      2
8	18/087	Screw, lever fulcrum ... ..	
9	18/053	Nut, fulcrum screw ... ..	
10	18/880	Nipple, slotted barrel ... ..	
<b>CONTROL CABLES—GROUP 17</b>			
<b>THROTTLE CABLE</b>			
11	D383	CABLE ASSEMBLY, THROTTLE ... ..	
12	D410	CABLE ASSEMBLY, THROTTLE ... .. (American Handlebar)	A      A
13	D101	Ferrule, throttle casing ... ..	3      3
14	H670	Guide tube, throttle wire ... ..	
15	D83	Nipple, twistgrip end ... ..	
16	D104	Adjusters assembly ... ..	
17	6/132A	Ferrule, at carburetter ... ..	
18	NS191	Nipple, at carburetter ... ..	
<b>FRONT BRAKE CABLE</b>			
19	D418	CABLE ASSEMBLY, FRONT BRAKE ... ..	
20	D419	CABLE, FRONT BRAKE ... .. (American Handlebar)	A      A
21	D103	Ferrule, casing ... ..	2      2
22	D368	Nipple, lever end ... ..	
23	W593	Fork end, lower ... ..	
<b>CLUTCH CABLE</b>			
24	D366	CABLE ASSEMBLY, CLUTCH ... ..	
25	D408	CABLE ASSEMBLY, CLUTCH ... .. (American Handlebar)	A      A
26	D103	Ferrule, casing ... ..	2      2
27	D368	Nipple lever end ... ..	
28	DS73	Nipple gearbox end ... ..	
29	XA69	Clip, cables to frame ... ..	as required

## PROPRIETARY GROUP

### PROPRIETARY GROUP

Ancillary equipment which is fitted to our motor cycles is of the highest quality and is guaranteed by the manufacturers and not by ourselves. Any repairs or claims should be made to the actual maker who will always give owners every possible assistance. The following are the addresses of the various manufacturers :

<b>CARBURETTORS</b> ... ..	Messrs. Amal Ltd., Holdford Road, Witton, Birmingham, 6.
<b>CHAINS</b> ... ..	The Renold and Coventry Chain Co. Ltd., Wythenshawe, Manchester.
<b>ELECTRICAL EQUIPMENT</b> ...	Messrs. J. Lucas, Ltd., Gt. Hampton Street, Birmingham, 18.
<b>SPARKING PLUGS</b> ... ..	Champion Sparking Plug Co. Ltd., Feltham, Middlesex.  K.L.G. Sparking Plugs Ltd., Cricklewood Works, London, N.W.2.  Lodge Plugs Ltd., Rugby, Warwickshire.
<b>SPEEDOMETERS</b> ... ..	Messrs. Smiths Motor Accessories Ltd., Cricklewood Works, London, N.W.2.
<b>SUSPENSION UNITS</b> ... ..	Messrs. Girling Ltd., Kings Road, Tyseley, Birmingham, 11.
<b>TYRES</b> ... ..	Dunlop Rubber Co. Ltd., Fort Dunlop, Birmingham, 24.

## GROUP 18 — CARBURETTER

REF. No.	PART No.	DESCRIPTION	QUANTITY	
			3TA	5TA
		<b>CARBURETTER—GROUP 18</b>		
1	375/32	CARBURETTER, COMPLETE, $\frac{3\frac{1}{2}}{32}$ " ... ..	1	—
2	375/35	CARBURETTER, COMPLETE, $\frac{7}{8}$ " ... ..	—	1
3	375/003	Body, mixing chamber, $\frac{35}{32}$ " ... ..	1	—
4	375/005	Body, mixing chamber, $\frac{7}{8}$ " ... ..	—	1
5	375/057	Block, jet, $\frac{3\frac{1}{2}}{32}$ " ... ..	1	—
6	375/059	Block, jet, $\frac{7}{8}$ " ... ..	—	1
7	375/067	Washer, jet block ... ..	1	1
8	376/070	Peg, jet block locating ... ..	1	1
9	375/102	Air valve assembly ... ..	1	1
10	375/065	Cap ring, mixing chamber ... ..	1	1
11	375/071	Spring, cap ring ... ..	1	1
12	4/241	Screw, cap spring ... ..	1	1
13	375/060	Valve, throttle ( $3\frac{1}{2}$ cutaway) ... ..	1	—
14	375/060	Valve, throttle (3 cutaway) ... ..	—	1
15	375/079	Spring, throttle valve ... ..	1	1
16	375/063	Needle, throttle valve ("B") ... ..	1	1
17	4/230	Clip, needle ... ..	1	1
18	376/072	Jet, needle (.105) ... ..	1	1
19	376/100	Jet, main (100) ... ..	1	—
20	376/100	Jet, main (160) ... ..	—	1

### INDEX TO FIG. 19

Illust. No.	Part No.	Page No.	Ref. No.	Illust. No.	Part No.	Page No.	Ref. No.
1	375/102	56	9	16	376/073	58	1
2	375/065	56	10	17	376/100	56	19
3	375/071	56	11	18	376/075	58	3
4	4/241	56	12	19	375/057	56	5
5	375/079	56	15		375/059	56	6
6	375/060	56	13	20	376/091	58	17
7	375/063	56	16	21	F4308	46	25
8	375/003	56	3	22	376/093	58	16
	375/005	56	4	23	E3985	58	31
9	244/765	58	25	24	229/048	58	26
10	332/017	58	7	25	376/088	58	15
11	376/070	56	8	26	376/077	58	22
12	376/072	56	18	27	376/079	58	24
13	376/068	58	9	28	376/094	58	13
14	376/076	58	4	29	376/083	58	11
15	376/095	58	5	30	376/089	58	14



# CARBURETTER — GROUP 18

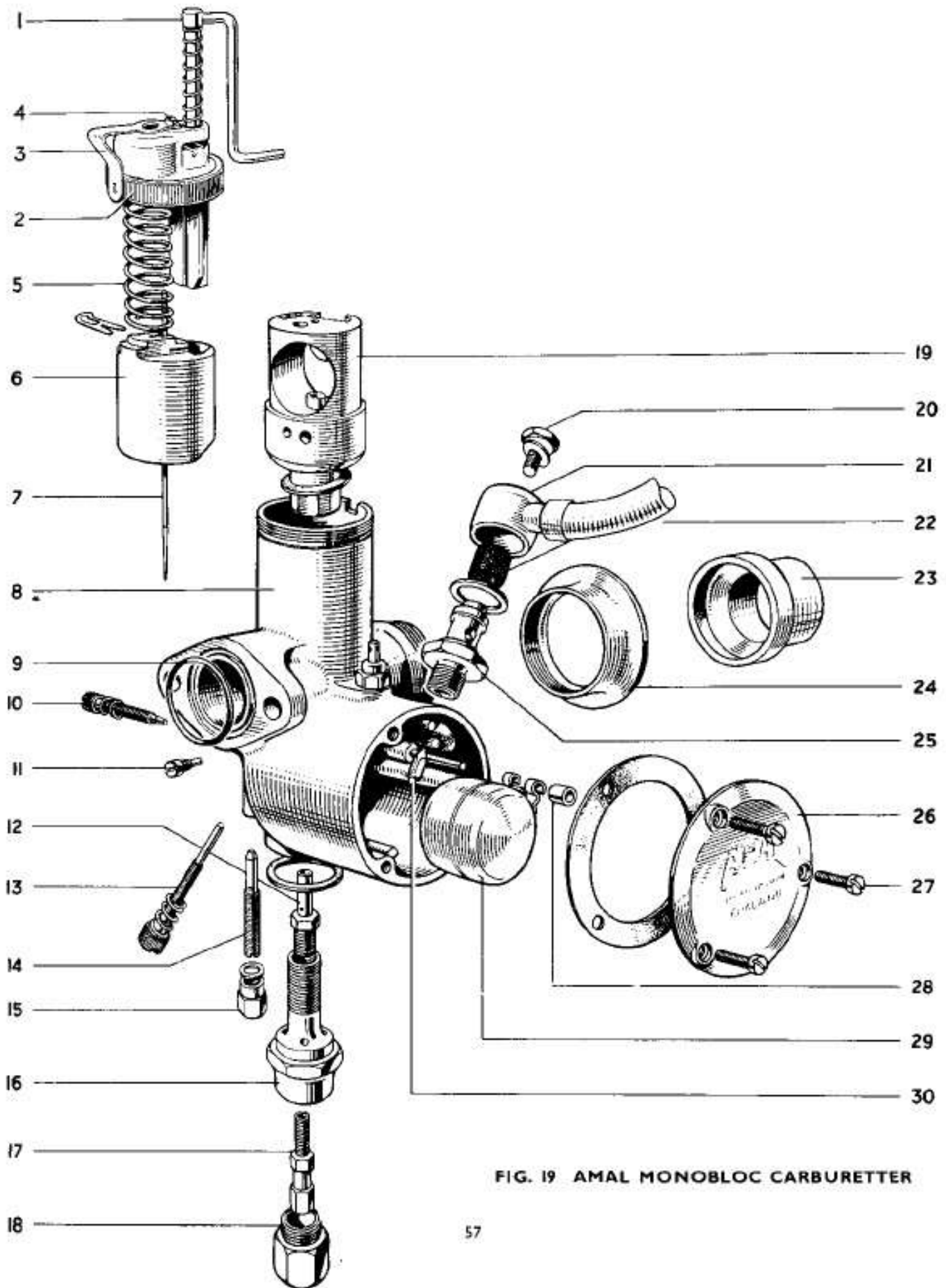

FIG. 19 AMAL MONOBLOC CARBURETTER

**GROUP 18 — CARBURETTER****GROUP 19 — AIR FILTER****GROUP 20 — CHAINS**

REF. No.	PART No.	DESCRIPTION	QUANTITY	
			3TA	5TA
1	376/073	Holder, main jet ... ..		
2	376/074	Washer, jet holder ... ..		
3	376/075	Nut, main jet cover ... ..		
4	376/076	Jet, pilot (25) ... ..		
5	376/095	Nut, pilot jet cover ... ..		
6	116/162	Washer, cover nut ... ..		
7	332/017	Screw, air adjusting ... ..		
8	4/148	Spring, air adjusting screw ... ..		
9	376/068	Screw, throttle stop ... ..		
10	376/069	Spring, stop screw ... ..		
11	376/083	Float ... ..		
12	376/085	Spindle, float hinge ... ..		
13	376/094	Bush, float spindle ... ..		
14	376/089	Needle, float ... ..		
15	376/088	Seating, needle ... ..		
16	376/093	Filter, nylon gauze ... ..		
17	376/091	Bolt, banjo ... ..		
18	376/092	Washer, banjo bolt ... ..		
19	376/086	Tickler ... ..		
20	343/011	Body, tickler ... ..		
21	376/087	Spring, tickler ... ..		
22	376/077	Cover, float chamber ... ..		
23	376/078	Washer, cover joint ... ..		
24	376/079	Screw, cover ... ..	3	3
25	244/765	"O" ring, carburetter to manifold ... ..		
26	229/048	Tube, air intake ... ..	A	A
<b>AIR FILTER—GROUP 19</b>				
27	F4218	Air filter ... ..		
28	DS57	Bolt, filter to frame, $\frac{1}{16}$ " U.H. ... ..		
29	S25-43	Washer, plain ... ..		
30	F879	Nut ... ..		
31	E3985	Connection, rubber carburetter to filter ... ..		
32	F3859	Clip, connection to carburetter ... ..		
<b>CHAINS—GROUP 20</b>				
33	D358	Chain, primary 78L $\times \frac{3}{8}$ " $\times \frac{1}{4}$ " Duplex ... ..		
34	D304	Chain, rear 100L $\times \frac{5}{8}$ " $\times \frac{3}{8}$ " ... ..		-
35	D310	Chain, rear 101L $\times \frac{5}{8}$ " $\times \frac{3}{8}$ " ... ..	-	
36	110056/59	Kit, rear chain spares ... ..		

## ELECTRICAL EQUIPMENT — GROUP 21

REF. No.	PART No.	DESCRIPTION	3TA	5TA
<b>ELECTRICAL EQUIPMENT—GROUP 21</b>				
<b>ALTERNATOR</b>				
1	423506	Rotor ... ..	1	1
2	E3851	Key, rotor to shaft ... ..	1	1
3	468973	STATOR, complete ... ..	1	1
4	862898	Cable, stator output ... ..	1	1
5	E3811	Stud, stator to crankcase, $3\frac{5}{16}$ " O.A. ... ..	3	3
6	E3810	Distance piece, stator ... ..	3	3
7	S25-3	Washer, plain ... ..	3	3
8	S1-51	Nut, stator fixing ... ..	3	3
9	E3764	Ring, cable sealing (rubber) ... ..	1	1
10	E3765	Nut, cable sealing ... ..	1	1
11	E1509	Clip, cable to crankcase ... ..	1	1
12	T361	Bolt, clip, $\frac{1}{2}$ " U.H. ... ..	1	1
<b>AMMETER</b>				
13	36189A	Ammeter, type BM4 ... ..	1	1
<b>BATTERY</b>				
14	PUZ7E-11	Battery ... ..	1	1
15	F4219	Carrier, battery ... ..	1	1
16	F4485	Rod, battery clamp ... ..	1	1
* 17	F879	Nut, clamp rod ... ..	1	1
<b>COIL</b>				
18	45077A	Coil, 6 volt MA6 ... ..	1	1
19	100104	Screw, clip ... ..	1	1
20	169160	Nut, square ... ..	1	1
21	422369	Packing piece "D" ... ..	2	2
22	DS57	Bolt, coil to frame, $\frac{7}{16}$ " U.H. ... ..	2	2
23	F879	Nut, coil bolt ... ..	2	2
24	E2312	Washer, shakeproof ... ..	2	2
25	422567	Grommet, rubber ... ..	1	1
26	421863	Clip, cable contact ... ..	1	1
<b>DISTRIBUTOR</b>				
27	40573A	DISTRIBUTOR ... ..	1	—
28	40646	DISTRIBUTOR ... ..	—	1
29	425049	Cap assembly ... ..	1	1
30	404435	Brush and spring ... ..	1	1
31	421554	Grommet, rubber cable ... ..	3	3
32	421863	Clip, cable contact ... ..	3	3
33	423486	Rotor ... ..	1	1
34	423110	Bush, shaped insulating ... ..	1	1
35	423108	Connector, terminal to condenser ... ..	1	1
36	423109	Bush, insulating ... ..	1	1
37	421748	Condenser ... ..	1	1
38	421569	Cover, rubber condenser ... ..	1	1

## GROUP 21 — ELECTRICAL EQUIPMENT

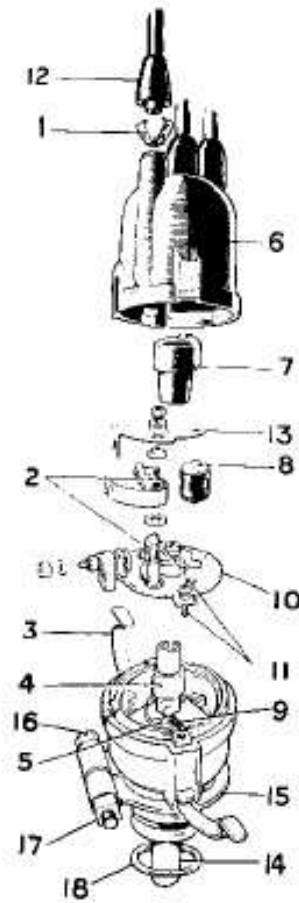

FIG. 20 LUCAS DISTRIBUTOR TYPE 18D2

### INDEX TO FIG. 20

Illust. No.	Part No.	Page No.	Ref. No.	Illust. No.	Part No.	Page No.	Ref. No.
1	421863	59	32	10	423113	61	2
2	425219	61	1	11	425243	61	11
3	424158/S	61	9	12	421554	59	31
4	424972	61	3	13	423108	59	35
5	421056/S	61	6	14	424967	61	8
6	425049	59	29	15	E3825	61	13
7	423486	59	33	16	112917	61	16
8	421748	59	37	17	173857	61	18
9	422655/S	61	4	18	188639	61	12
	54410895/S	61	5				

## ELECTRICAL EQUIPMENT — GROUP 21

REF. No.	PART No.	DESCRIPTION	3TA	5TA
1	425219	Contact set	1	1
2	423113	Plate, contact breaker base	1	1
3	424972	Cam	1	1
4	422655/S	Spring set	1	—
5	54410895/S	Spring set	—	1
6	421056/S	Weight set	1	1
7	424974	Cup, thrust, sealing	1	1
8	424967	Shaft and action plate	1	1
9	424158/S	Clip, cap retaining	1	1
10	423571	Bush, shaft	1	1
11	425243	Sundry parts set	1	1
12	188639	Ring, sealing	1	1
13	E3825	Plate, distributor clamp	1	1
14	D557	Bolt, clamp plate to crankcase, $\frac{7}{16}$ " U.H.	1	1
15	S25-3	Washer, plain	1	1
16	112917	Bolt, distributor clamp	1	1
17	185051	Washer, spring	1	1
18	173857	Nut, clamp bolt	1	1
19	E3863	Sheath, distributor leads	1	1
<b>HORN</b>				
20	70148A	Horn	1	1
21	701851	Bracket, triangular	2	2
22	H1172	Bracket, angle (to handlebar "U" bolt nuts)	1	1
23	142689	Screw, horn bracket	2	2
24	185051	Washer, bracket screw	2	2
<b>HEADLAMP</b>				
25	51860A	HEADLAMP ASSEMBLY	1	1
26	553248	Rim, front	1	1
27	555309	Glass and reflector light unit	1	1
28	504665	Fixing wire, light unit	6	6
29	373	Bulb, prefocus 30/24W	1	1
30	554602	Adaptor, bulb	1	1
31	988	Bulb, pilot 3W	1	1
32	554710	Bulbholder, pilot	1	1
33	553267	Ring, lamp fixing	1	1
34	144921	Screw, rim fixing	1	1
35	554408	Plate, rim fixing	1	1
36	H689	Screw, fixing ring, $\frac{1}{4}$ " U.H.	2	2
37	H690	Nut, fixing screw	2	2

## GROUP 21 — ELECTRICAL EQUIPMENT

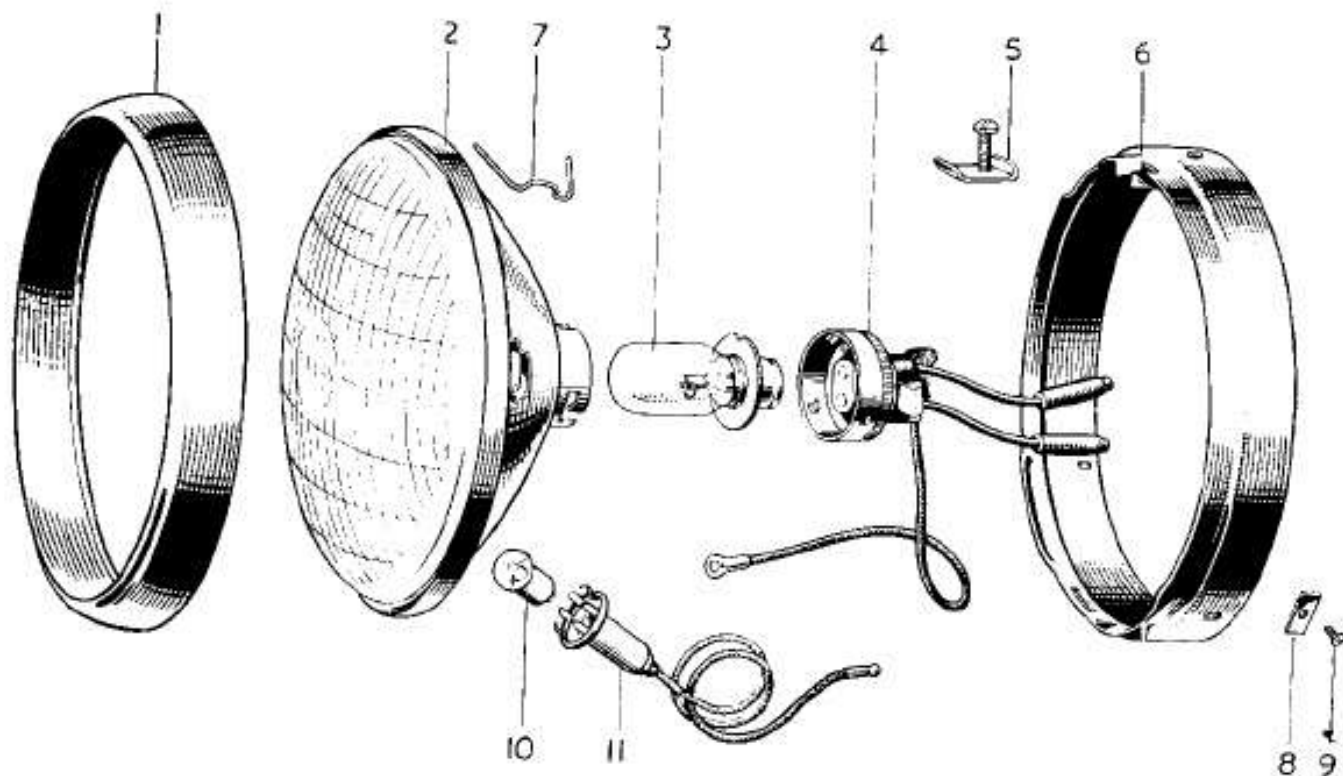

FIG. 21 LUCAS HEADLAMP TYPE MCF700P

### INDEX TO FIG. 21

<i>Illust. No.</i>	<i>Part No.</i>	<i>Page No.</i>	<i>Ref. No.</i>	<i>Illust. No.</i>	<i>Part No.</i>	<i>Page No.</i>	<i>Ref. No.</i>
1	553248	61	26	6	553267	61	33
2	555309	61	27	7	504665	61	28
3	373	61	29	8	H690	61	37
4	554602	61	30	9	H689	61	36
5	144921	61	34	10	988	61	31
	554408	61	35	11	554710	61	32

## ELECTRICAL EQUIPMENT — GROUP 21

REF. No.	PART No.	DESCRIPTION	3TA	5TA
<b>REAR LAMP</b>				
1	53432B	LAMP, STOP AND TAIL ... ..	1	1
2	573839	Lens ... ..	1	1
3	575200	Window ... ..	1	1
4	575208	Gasket, lens seating ... ..	1	1
5	575219	Nut, lens retaining ... ..	2	2
6	576002	Base assembly ... ..	1	1
7	575209	Bulbholder ... ..	1	1
8	575207	Grommet, bulbholder ... ..	1	1
9	573828	Contact assembly ... ..	1	1
10	573825	Grommet, cable ... ..	1	1
11	384	Bulb, 6/18W, offset pin ... ..	1	1
<b>RECTIFIER</b>				
12	47111A	Rectifier ... ..	1	1
13	F3600	Nut, rectifier to frame ... ..	1	1
<b>LIGHTING AND IGNITION SWITCH</b>				
14	31443E	LIGHTING AND IGNITION SWITCH ... ..	1	1
15	318323	Grommet, for key ... ..	1	1
16	318241	Key ... ..	1	1
17	319333	Screw, for knob ... ..	1	1
18	318346	Knob ... ..	1	1
19	318343	Plate, index ... ..	1	1
<b>HORN PUSH AND DIP SWITCH</b>				
20	31563A	Horn push and dip switch ... ..	1	1
21	863082	Cable, dip switch ... ..	1	1
22	H689	Screw, switch to clutch lever, $\frac{1}{2}$ " U.H. ... ..	2	2
<b>STOP LAMP SWITCH</b>				
23	31688A	Switch, stop lamp ... ..	1	1
24	360363	Cover, rubber terminal ... ..	1	1
<b>WIRING HARNESS</b>				
25	838601	Wiring harness ... ..	1	1
26	862566	Grommet, at rectifier ... ..	1	1
27	838604	Lead, twin stop-tail lamp ... ..	1	1
28	900288	Connector, snap ... ..		as required
29	900269	Nipple, snap connector ... ..		as required

**GROUP 22 — SPARKING PLUGS**  
**GROUP 23 — SPEEDOMETER**  
**GROUP 24 — SUSPENSION UNITS**

REF. No.	PART No.	DESCRIPTION	QUANTITY	
<b>SPARKING PLUGS—GROUP 22</b>				
			3TA	5TA
1	N3	Plug, sparking (Champion) ... ..	A	A
2	HLN	Plug, sparking (Lodge) ... ..	A	A
3	FE75	Plug, sparking (K.L.G.) ... ..	A	A
4	D297	Cover and suppressor, plug ... ..	2	2
<b>SPEEDOMETER—GROUP 23</b>				
5	S467/227	Speedometer head M.P.H. ... ..	1	1
6	S467/231N	Speedometer head K.P.H. ... ..	A	A
7	P53279/1	BULB HOLDER C/W BULB ... ..	1	1
8	P52305	Bulb only ... ..	1	1
9	P22469	Rubber ring, speedometer head ... ..	1	1
10	25578/2	Clamp bar ... ..	1	1
11	N1253	Nut, clamp bar ... ..	2	2
12	D356	Cable, speedometer drive, 58" long ... ..	1	1
<b>SUSPENSION UNITS—GROUP 24</b>				
13	64053946	SUSPENSION UNIT, COMPLETE ... ..	2	—
14	64053945	SUSPENSION UNIT, COMPLETE ... ..	—	2
15	9054/151	Dirt shield, outer ... ..	2	2
16	9054/171	Retainer, split ... ..	4	4
17	9054/47	Dirt shield, inner ... ..	2	2
18	9054/280	Spring, 100 lbs. rate ... ..	2	2
19	9054/316A	Bush and sleeve, bonded ... ..	4	4
20	E2113	Bolt, unit fixing, 1 <sup>3</sup> / <sub>16</sub> " U.H. ... ..	4	4
21	F2184	Washer, bottom bolts ... ..	2	2
22	P0172A	Nut, fixing bolt ... ..	4	4
23	S26-1	Washer, spring ... ..	4	4



## SUSPENSION UNITS — GROUP 24

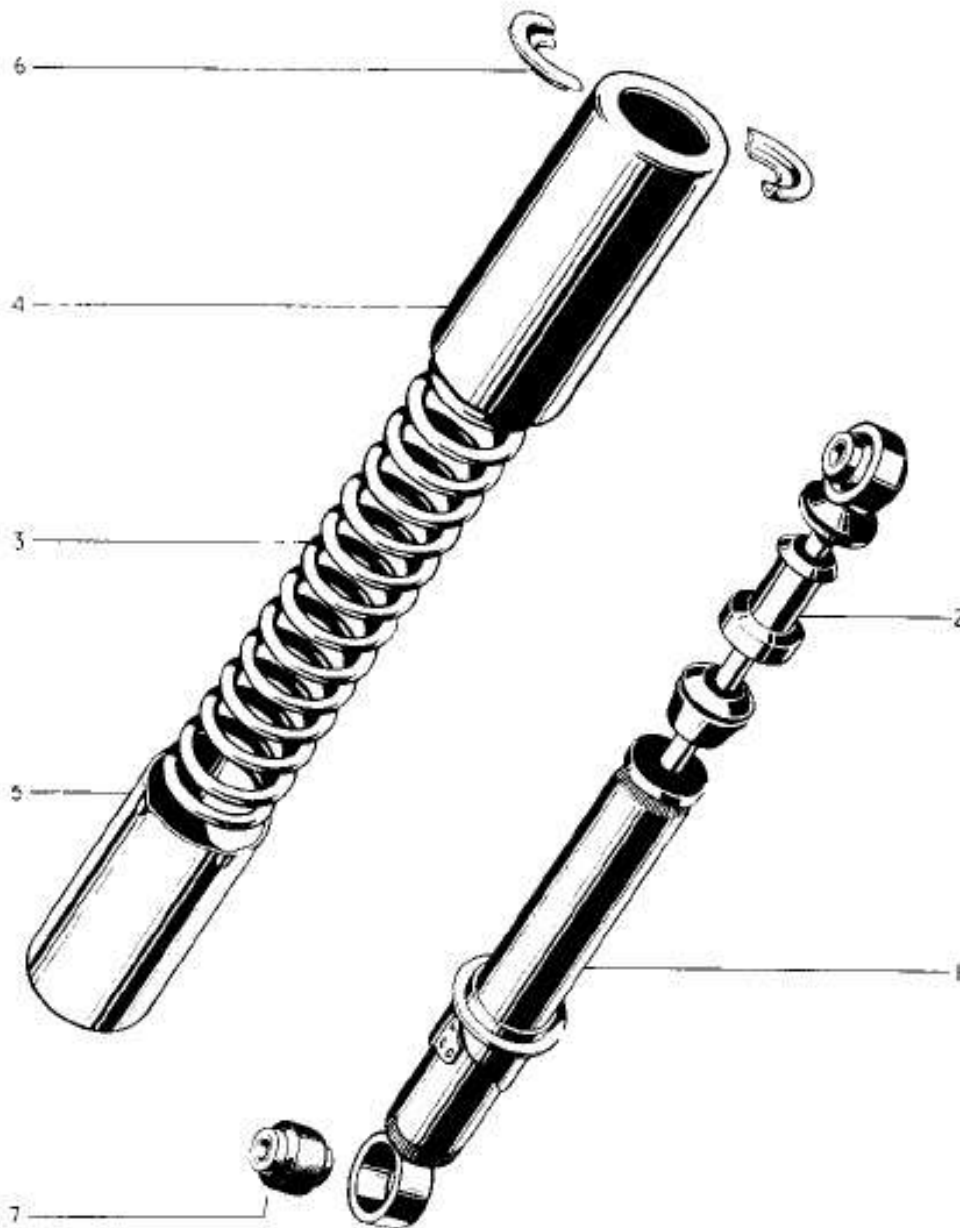

FIG. 22 GIRLING SUSPENSION UNIT

### INDEX TO FIG. 22

Illust. No.	Part No.	Page No.	Ref. No.	Illust. No.	Part No.	Page No.	Ref. No.
1	64053946	64	13	4	9054/151	64	15
	64053945	64	14	5	9054/47	64	17
2	Not serviced separately			6	9054/171	64	16
3	9054/280	64	18	7	9054/316A	64	19

# GUARANTEE

**WE** give the following guarantee with our motor cycles, motor cycle combinations and sidecars. This guarantee is given in place of any implied conditions or warranties or any liabilities whatsoever statutory or otherwise; no guarantee except that hereinafter contained and no conditions or warranty whatsoever statutory or otherwise is given or is to be implied, nor are we to be under any liability whatsoever except under the guarantee hereinafter contained. Any statement, description, condition or representation contained in any catalogue, advertisement, leaflet or other publication shall not be construed as enlarging, varying or overriding anything herein contained. In the case of machines (a) which have been used for "hiring out" purposes or (b) any motor cycle and/or sidecar used for any dirt tracks, cinder tracks or grass track racing or competitions (or any competition of any kind within an enclosure for which a charge is made for admission to take part in or view the competition) or (c) machines from which the trade mark, name or manufacturing number has been altered or removed or (d) any machines in which parts have been used not supplied by or approved by the motor cycle manufacturer, or (e) any machine from which the silencing system as fitted by the manufacturer has been partially or wholly removed or interfered with, no guarantee, condition or warranty of any kind statutory or otherwise is given or is to be implied nor are we to be under any liability whatsoever in respect of any such machine.

We guarantee, subject to the conditions mentioned below, that all precautions which are usual and reasonable have been taken by us to secure excellence of materials and workmanship, but this guarantee is to extend and be in force for six months only in the U.K. and ninety days overseas from date of purchase, or date of exchange in case of any part supplied by way of exchange as hereinafter provided, and damages for which we make ourselves responsible under this guarantee are limited to the free repair of or supply of a new part in exchange for the part of the motor cycle, motor cycle combination or sidecar which may have proved defective. We undertake, subject to the conditions mentioned below, to make good in manner aforesaid any part covered by this guarantee which has proved defective within the said period. We do not undertake to replace or refix, or bear the cost of replacing or refixing any such new part in the motor cycle, motor cycle combination or sidecar. As motor cycles, motor cycle combinations and sidecars are easily liable to derangement by neglect or misuse, this guarantee does not apply to defects caused by wear and tear, misuse or neglect.

The term "misuse" shall include amongst others the following acts:—

1. The attaching of a sidecar to a motor cycle in such a manner as to cause damage or calculated to render the latter unsafe when ridden.
2. The use of a motor cycle or of a motor cycle and sidecar combined, when carrying more persons or a greater weight than that for which the machine was designed by the manufacturers.
3. The attaching of a sidecar to a motor cycle by any form of attachment not provided, supplied, or approved by the manufacturers, or to a motor cycle which is not designed for such use.

We do not guarantee specialities such as tyres, saddles, chains, carburetters, electrical equipment, lamps, etc., or any accessories or component parts supplied to the order of the purchaser differing from those comprised in the standard specifications supplied with our motor cycles, motor cycle combinations or sidecars. As regards all such specialities, accessories or component parts, no guarantee, condition, or warranty of any kind statutory or otherwise is given or is to be implied, and we are to be under no liability whatsoever in respect thereof.

## **CONDITIONS OF GUARANTEE**

If a defective part should be found in our motor cycles, motor cycle combinations or sidecars, or in any part supplied by way of exchange as before provided, it must be sent to us CARRIAGE PAID, and accompanied by an intimation from the owner that he desires to have it repaired or exchanged free of charge under our guarantee and he must also furnish us at the same time with the frame number of the machine, the date of purchase or the date when the alleged defective part was exchanged as the case may be.

Failing compliance with the above, such articles will lie here at THE RISK OF THE OWNER, and this guarantee and any implied guarantee, warranty or condition, shall not be enforceable.

## **REPAIRS**

Any motor cycle, motor cycle combination or sidecar sent to us to be plated, enamelled or repaired will be repaired upon the following conditions, i.e., we guarantee that all precautions which are usual and reasonable have been taken by us to secure excellence of materials and workmanship, such guarantee to extend and be in force for three months only from the time such work shall have been executed, and this guarantee is in lieu and in exclusion of all conditions and warranties statutory or otherwise and all liabilities whatsoever and the damages recoverable are limited to the cost of any further work which may be necessary to amend and make good the work found to be defective.

## **NOTICE**

We do not appoint agents for the sale on our behalf of our motor cycles or other goods, but we assign to motor cycle Dealer areas in which we supply to such Dealers exclusively for re-sale in such areas. No such Dealer is authorised to transact any business, give any warranty, make any representation or incur any liability on our behalf. All goods are offered for sale subject to the price ruling at time of delivery. We reserve the right to modify or deviate from the published specification.

# INDEX

	Page No.
<b>Group 1—CARTON PACKS</b> ... ..	5
<b>Group 2—ENGINE</b> ... ..	9
Cylinder block ... ..	9
Pistons ... ..	9
Cylinder head and valve guides ... ..	9
Inlet manifold ... ..	10
Valve and springs ... ..	10
Rocker boxes and rocker gear ... ..	10
Rocker oil feed pipe ... ..	12
Crankshaft ... ..	12
Connecting rods ... ..	12
Crankcase ... ..	16
Crankcase fittings ... ..	17
Timing gears and camshafts ... ..	19
Tappets and push rods ... ..	19
Oil pump ... ..	19
Timing cover ... ..	20
Oil pressure release valve ... ..	20
Engine sprocket ... ..	20
<b>Group 3—GEARBOX</b> ... ..	22
Shafts and Gears ... ..	22
Gearbox bearings ... ..	22
Gearbox casing fittings ... ..	22
Gearchange mechanism ... ..	24
Inner cover and kickstarter ... ..	24
Outer cover and clutch lever ... ..	24
Gearchange and kickstart levers ... ..	26
Gearbox sprocket and cover plate ... ..	26
Clutch and shock absorber ... ..	26
Chaincase cover ... ..	29
<b>Group 4—EXHAUST SYSTEM</b> ... ..	29
<b>Group 5—FRAME</b> ... ..	30
Engine plates and studs ... ..	30
Engine torque stays ... ..	30
Swinging fork ... ..	31
Centre stand ... ..	31
Prop stand ... ..	31
Footrests ... ..	31
Brake pedal ... ..	32

<b>Group 6—TELESCOPIC FRONT FORK</b>	...	...	...	...	...	...	...	...	...	...	34
Steering races	...	...	...	...	...	...	...	...	...	...	37
Nacelle top and motifs	...	...	...	...	...	...	...	...	...	...	37
<b>Group 7—FRONT WHEEL</b>	...	...	...	...	...	...	...	...	...	...	38
Front brake	...	...	...	...	...	...	...	...	...	...	40
<b>Group 8—REAR WHEEL</b>	...	...	...	...	...	...	...	...	...	...	42
Rear brake	...	...	...	...	...	...	...	...	...	...	42
Speedometer drive	...	...	...	...	...	...	...	...	...	...	42
Chain adjusters	...	...	...	...	...	...	...	...	...	...	42
<b>Group 9—FRONT MUDGUARD</b>	...	...	...	...	...	...	...	...	...	...	43
Front stand	...	...	...	...	...	...	...	...	...	...	43
Front number plate	...	...	...	...	...	...	...	...	...	...	43
Licence holder	...	...	...	...	...	...	...	...	...	...	43
<b>Group 10—REAR MUDGUARD AND PANELS</b>	...	...	...	...	...	...	...	...	...	...	43
Rear mudguard	...	...	...	...	...	...	...	...	...	...	43
Rear panels	...	...	...	...	...	...	...	...	...	...	43
Rear number plate	...	...	...	...	...	...	...	...	...	...	44
<b>Group 11—REAR CHAINGUARDS</b>	...	...	...	...	...	...	...	...	...	...	44
Upper rear chainguard	...	...	...	...	...	...	...	...	...	...	44
Lower rear chainguard	...	...	...	...	...	...	...	...	...	...	44
<b>Group 12—PETROL TANK</b>	...	...	...	...	...	...	...	...	...	...	46
Petrol tap and pipe	...	...	...	...	...	...	...	...	...	...	46
Parcel grid	...	...	...	...	...	...	...	...	...	...	48
<b>Group 13—OIL TANK</b>	...	...	...	...	...	...	...	...	...	...	48
Oil filter and pipes	...	...	...	...	...	...	...	...	...	...	48
<b>Group 14—TOOLKIT</b>	...	...	...	...	...	...	...	...	...	...	48
<b>Group 15—TWINSEAT</b>	...	...	...	...	...	...	...	...	...	...	50
<b>Group 16—HANDLEBARS</b>	...	...	...	...	...	...	...	...	...	...	52
Throttle control	...	...	...	...	...	...	...	...	...	...	52
Front brake control	...	...	...	...	...	...	...	...	...	...	52
Clutch control	...	...	...	...	...	...	...	...	...	...	54

<b>Group 17—CONTROL CABLES</b>	...	...	...	...	...	...	...	...	...	54
--------------------------------	-----	-----	-----	-----	-----	-----	-----	-----	-----	----

## PROPRIETARY FITTINGS

<b>Group 18—CARBURETTER</b>	...	...	...	...	...	...	...	...	...	56
-----------------------------	-----	-----	-----	-----	-----	-----	-----	-----	-----	----

<b>Group 19—AIR FILTER</b>	...	...	...	...	...	...	...	...	...	58
----------------------------	-----	-----	-----	-----	-----	-----	-----	-----	-----	----

<b>Group 20—CHAINS</b>	...	...	...	...	...	...	...	...	...	58
------------------------	-----	-----	-----	-----	-----	-----	-----	-----	-----	----

<b>Group 21—ELECTRICAL EQUIPMENT</b>	...	...	...	...	...	...	...	...	...	59
--------------------------------------	-----	-----	-----	-----	-----	-----	-----	-----	-----	----

Alternator	...	...	...	...	...	...	...	...	...	59
Ammeter	...	...	...	...	...	...	...	...	...	59
Battery	...	...	...	...	...	...	...	...	...	59
Coil	...	...	...	...	...	...	...	...	...	59
Distributor	...	...	...	...	...	...	...	...	...	59
Horn	...	...	...	...	...	...	...	...	...	61
Headlamp	...	...	...	...	...	...	...	...	...	61
Rear lamp	...	...	...	...	...	...	...	...	...	63
Rectifier	...	...	...	...	...	...	...	...	...	63
Switches	...	...	...	...	...	...	...	...	...	63
Wiring harness	...	...	...	...	...	...	...	...	...	63

<b>Group 22—SPARKING PLUGS</b>	...	...	...	...	...	...	...	...	...	64
--------------------------------	-----	-----	-----	-----	-----	-----	-----	-----	-----	----

<b>Group 23—SPEEDOMETER</b>	...	...	...	...	...	...	...	...	...	64
-----------------------------	-----	-----	-----	-----	-----	-----	-----	-----	-----	----

<b>Group 24—SUSPENSION UNITS</b>	...	...	...	...	...	...	...	...	...	64
----------------------------------	-----	-----	-----	-----	-----	-----	-----	-----	-----	----

# INDEX TO ILLUSTRATIONS

	Page No.
Fig. 1. Inlet manifold ... ..	11
„ 2. Cylinder block and head 3TA ... ..	13
„ 3. Cylinder block and head 5TA ... ..	14
„ 4. Crankshaft and connecting rods ... ..	15
„ 5. Crankcase and covers... ..	18
„ 6. Shafts and gears ... ..	23
„ 7. Gearbox inner cover ... ..	25
„ 8. Gearbox outer cover ... ..	27
„ 9. Clutch and shock absorber ... ..	28
„ 10. Frame and fittings ... ..	33
„ 11. Telescopic front fork ... ..	35
„ 12. Front wheel ... ..	39
„ 13. Rear wheel ... ..	41
„ 14. Rear mudguard, chainguard and panels ... ..	45
„ 15. Petrol and oil tanks ... ..	47
„ 16. Toolkit ... ..	49
„ 17. Twinseat and fittings ... ..	51
„ 18. Handlebar and controls ... ..	53
„ 19. Amal monobloc carburetter ... ..	57
„ 20. Lucas distributor Type 18D2 ... ..	60
„ 21. Lucas headlamp Type MCF700P ... ..	62
„ 22. Girling suspension unit ... ..	65

To assist the owner and dealer in identifying requirements, this book contains numerous exploded views of the major assemblies. Each component part on the illustration is numbered, and by cross reference to the appropriate index, the part number of the component will be found. Against each part number a page and reference number is shown and by referring to the appropriate page, the full description of the part will be found against the reference number.

## EXAMPLE

To find the part number of the cylinder head gasket :

1. Refer to the illustration index above, where it will be found that the engine is illustrated on page 13.
2. Note that the number of the gasket in the illustration is 38.
3. Refer to the index on page 13.
4. Note that illustration number 38 is part number E3769 listed on page 9, line 22.

*Tournez s'il vous plait.  
Yease of dorso.  
Bitte wenden.*

## MANIÈRE D'IDENTIFIER LA PIÈCE DE RECHANGE REQUISE

Afin d'assister MM. les marchands et MM. les possesseurs à l'identification des pièces de rechange, ce livre contient de nombreuses illustrations des montages principaux en façon de "perspectives éclatées".

Chaque pièce composante à l'illustration est numérotée ; en se référant à l'index approprié on peut trouver le numéro relatif.

À côté de chaque pièce illustrée se trouve le numéro de la page et le numéro de référence ; en se référant à la page appropriée la description complète de la pièce sera facilement constatée.

### Exemple.

Pour identifier le numéro de référence du joint de culasse :

1. Se référer à la page intitulée "Index to Illustrations" où on trouvera que le moteur est illustré sur la page 13.
2. Noter qu'à côté du joint de culasse se trouve le numéro 38.
3. Se référer à l'index donné sur la page numéro 13.
4. On y constatera que suivant le numéro 38 se trouve :
  - (a) le numéro relatif—E3769
  - (b) le numéro de la page d'index—9
  - (c) la ligne de référence—22.

---

## MANERA DE ENCONTRAR LA PIEZA DESEADA

Para ayudar al propietario y al representante en la identificación de las piezas deseadas este libro contiene numerosas ilustraciones de los principales montajes.

Cada pieza componente en la ilustración está numerada y al referirse al índice apropiada, se encontrará el número de la pieza.

Contra el número de cada pieza se muestra el número de referencia, y al referirse a la página apropiada a descripción completa de cada pieza se encontrará contra el número de referencia.

### Ejemplo.

Para encontrar el número de pieza de la empaquetadura de la culata de cilindro :

1. Referirse a la página "Index to Illustrations" donde se verá que la ilustración del motor está en la página 13.
2. Nótese que el número de la empaquetadura en la ilustración es 38.
3. Referirse al índice de la ilustración en cuestión en la página 13.
4. Nótese que no. 38 es pieza número E3769 en la lista de la página 9, línea de referencia no. 22.

---

## ANWEISUNG ZUR IDENTIFIZIERUNG BENOETIGTER ERSATZTEILE

Dieses Buch enthält zahlreiche Zerlege-Abbildungen der Hauptzusammenstellungen, um dem Besitzer und dem Verteiler beim Identifizieren seiner Forderungen zu helfen. Jedes Teil auf der Abbildung ist mit einer Nummer versehen, und die Bestandteilnummer wird durch Nachschlagen des bezüglichen Verzeichnisses gefunden. Mit jeder Teilnummer ist die Seite und die Referenznummer gegeben, und durch Nachschlagen der bezüglichen Seite wird die vollständige Beschreibung des Teiles unter der Referenznummer gefunden.

### Zum Beispiel.

Um die Nummer der Zylinderkopfdichtung zu finden :

1. Schlagen Sie das Abbildungsverzeichnis, oben, nach, wo es gefunden wird, dass die Maschine auf Seite 13 abgebildet ist.
2. Merken Sie, dass Nr. 38 ist die Nummer der Dichtung auf der Abbildung.
3. Schlagen Sie das Verzeichnis auf Seite 13, nach.
4. Merken Sie, dass die Abbildungsnummer 38 ist die Teilnummer E3769, eingetragen auf Seite 9 Zeile 22.